

PowerEdge M820

Technical Guide

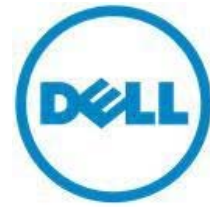

The PowerEdge M820 full-height blade delivers exceptional performance and scalability.

This document is for informational purposes only. Dell reserves the right to make changes without further notice to any products herein. The content provided is as is and without express or implied warranties of any kind.

Dell, the DELL logo, PowerEdge, EqualLogic, PowerVault, OpenManage and KACE are trademarks of Dell, Inc. Intel and Xeon are registered trademarks of Intel Corporation in the U.S. and other countries. Microsoft, Windows, Windows Server, ActiveX, Internet Explorer, and Hyper-V are either registered trademarks or trademarks of Microsoft Corporation in the United States and/or other countries. Novell and SUSE are registered trademarks of Novell, Inc. in the United States and other countries. IBM, Tivoli, and Netcool are registered trademarks of IBM in the United States. Other trademarks and trade names may be used in this document to refer to either the entities claiming the marks and names or their products. Dell disclaims proprietary interest in the marks and names of others.

©Copyright 2013 Dell Inc. All rights reserved. Reproduction or translation of any part of this work beyond that permitted by U.S. copyright laws without the written permission of Dell Inc. is unlawful and strictly forbidden.

December 2013 | Version 6.0



Table of contents

1	System overview	5
	Introduction	5
	New technologies	6
2	System features	7
	Comparison of PowerEdge systems	7
	Specifications	8
3	Module views and features	11
	Module views	11
	Module features	13
4	Processors	15
	Processor features	15
	Supported processors	16
	Chipset	16
5	Memory	17
	Supported memory	17
	Memory configurations	18
	Memory speed	19
	Memory RAS features	19
6	Storage	21
	Internal storage	21
	Storage controllers	22
7	Networking and mezzanine cards	24
	Select Network Adapters	24
	Mezzanine cards	26
8	Power, thermal and acoustics	27
	Power consumption and energy efficiency	27
	Power supply units	28
	Thermal and acoustics	28
9	Operating systems and virtualization	30
	Supported operating systems	30
	Supported virtualization	31
10	Dell OpenManage systems management	32
	Systems management solutions	32
	OpenManage systems management	33
	Dell server management operations	37
Appendix A.	Additional specifications	40
	Module dimensions and weight	40
	Video specifications	40
	Environmental specifications	41
	USB peripherals	42
Appendix B.	Standards compliance	43
Appendix C.	Additional resources	45
Appendix D.	System board block diagram	47



Tables

Table 1.	New technologies	6
Table 2.	Comparing the PowerEdge M910 and M820.....	7
Table 3.	Technical specifications	8
Table 4.	Module features.....	13
Table 5.	Supported processors	16
Table 6.	Memory technologies supported	17
Table 7.	DIMMs supported	18
Table 8.	Memory speed capabilities	19
Table 9.	Memory RAS features	20
Table 10.	Hard-drive backplane options	21
Table 11.	Supported hard drives.....	21
Table 12.	RAID controller feature support	22
Table 13.	Supported Select Network Adapter options and features	25
Table 14.	Supported mezzanine cards	26
Table 15.	Power tools and technologies.....	27
Table 16.	M820 acoustical performance	29
Table 17.	Primary operating system support	30
Table 18.	Virtual guest operating system support	30
Table 19.	Virtualization support	31
Table 20.	iDRAC7 with Lifecycle Controller functions and benefits.....	33
Table 21.	Feature comparison for iDRAC7 Enterprise and iDRAC7 Express for Blades	34
Table 22.	One-to-one and one-to-many operations	38
Table 23.	Supported video modes	40
Table 24.	Environmental specifications.....	41
Table 25.	Industry standard documents.....	43
Table 26.	Additional resources	45

Figures

Figure 1.	M820 front view	11
Figure 2.	M1000e chassis enclosure with M820 blades	12
Figure 3.	M820 internal module view.....	13
Figure 4.	QRL code located on module	14
Figure 5.	Blade network daughtercard	24
Figure 6.	Dell systems management solutions.....	32
Figure 7.	Systems management server lifecycle	38
Figure 8.	Module dimensions	40
Figure 9.	M820 system board block diagram	47



1 System overview

Introduction

The Dell™ PowerEdge™ M820's scalability makes it a perfect fit for core business applications or consolidated workloads. Virtual environments supporting large numbers of sizeable virtual machines will find the M820 a perfect choice. With up to four Intel® Xeon® E5-4600 processors and up to 1.5TB of RAM per node — 12TB of memory in just a single M1000e chassis — the M820's remarkable computational capability and memory scalability can address even the toughest demands. With Dell's Select Network Adapter, you can fully customize the I/O capabilities of the M820 to match the networking technology that's right for your applications.

Ensure business continuity

Ensure maximum uptime with the fully redundant M-series power, cooling and networking infrastructure designed to provide the stability and resiliency our customers demand for enterprise-class deployments. The M820's design matches Dell's commitment to reliability with features such as multiple hardware RAID choices and our unique failsafe virtualization technology, which utilizes redundant SD media to provide failover capabilities for embedded hypervisors.

Simplified systems management, without compromise

The Dell OpenManage™ portfolio includes Integrated Dell Remote Access Controller 7 (iDRAC7) with Lifecycle Controller. This embedded feature helps IT administrators manage Dell servers in physical, virtual, local and remote environments, operating in-band or out-of-band, with or without a systems management software agent installed. OpenManage iDRAC with Lifecycle Controller integrates and connects to leading third-party systems management solutions (such as those from Microsoft, VMware and BMC Software), so users can maintain a single point of control and capitalize on an existing systems management investment. OpenManage simplifies the lifecycle of deploying, updating, monitoring and maintaining Dell PowerEdge servers.

The PowerEdge M-series blade server line

Implement the right combination of features and performance scalability with the PowerEdge M-series blade servers that can handle tough workloads in a data center of any size. In addition to the world-class management features provided in all PowerEdge servers, the M820 also takes advantage of the capabilities of the M1000e's Chassis Management Controller (CMC). The CMC allows M-series blades to be managed individually or as groups, in single or multiple chassis, and within a data center or in multiple geographically dispersed locations around the globe without requiring an agent or additional hardware. PowerEdge M-series blade servers use the redundant power, cooling and networking infrastructure provided by the Dell M1000e blade enclosure, which is exceptionally easy to deploy and manage and maximizes power and cooling efficiency.



New technologies

A number of new technologies are featured on the PowerEdge M820 system, as shown in Table 1.

Table 1. New technologies

New technologies	Detailed descriptions
Intel Xeon processor E5-4600 product family	This new family of Intel processors has embedded PCI Express [®] (PCIe) lanes for improved I/O performance and additional new features. See the Processors section for details.
Intel C602 series chipset	The Intel Platform Controller Hub (PCH) chip is implemented on the M820.
LRDIMM	This new memory option, load reduced DIMM (LRDIMM), is designed with a buffer chip (or chips) to replace the register to help minimize loading. LRDIMMs can increase overall server system memory capacity and speed. See the Memory section for more information.
Flexible LOM	Dell's Select Network Adapter options allow you choose the right network fabric without using up a valuable mezzanine card slot. See the Networking and mezzanine cards section for details.
Next-generation PERC options	The M820 supports new Dell PERC controller cards with improved functionality and faster performance. See the Storage section for details.
Express Flash drives	Dell Express Flash PCIe solid-state drives (SSDs) provide fast performance without requiring processor resources or capturing DRAM. The M820 supports up to two Express Flash PCIe SSDs. See the Storage section for details.
iDRAC7 with Lifecycle Controller	The new embedded system management solution for Dell servers features hardware and firmware inventory and alerting, in-depth memory alerting, faster performance, a dedicated gigabit port and many more features. See the Systems management section for details.
Advanced power management	The M820 supports advanced power monitoring and power capping tools that can help manage power consumption in the data center.
Failsafe hypervisors	The internal dual SD module enables Dell's unique Failsafe Virtualization architecture, ensuring uptime by providing failover capability for embedded hypervisors, such as VMware [®] vSphere [®] ESXi [™] .
Fresh Air cooling	Dell has tested and validated an integrated data center solution that enables you to operate at higher temperatures or even chiller-less. See the Power, thermal and acoustics section for details.



2 System features

Compared to the previous generation of Dell PowerEdge blade servers, the M820 has more memory, processor cores and networking options than ever before. Features include DDR3 memory, PCIe 3.0, a network daughtercard (NDC), dual internal SD module and Dell's next-generation iDRAC solution known as iDRAC7 Enterprise with Lifecycle Controller.

Comparison of PowerEdge systems

The PowerEdge M820 is a replacement for the M910 system. Table 2 compares the features of both systems. For the latest information on supported features, visit Dell.com/PowerEdge.

Table 2. Comparing the PowerEdge M910 and M820

Feature	PowerEdge M910	PowerEdge M820
Chassis; enclosure	Full-height blade; PowerEdge M1000e Blade Enclosure	Full-height blade; PowerEdge M1000e Blade Enclosure
Processors	Intel Xeon processors 6500 and 7500 series, Intel Xeon processors E7-2800, E7-4800 and E7-8800 product families	Intel Xeon processor E5-4600 product family
Internal interconnect	Intel QuickPath Interconnect	Intel QuickPath Interconnect
Memory	32 x DDR3 RDIMM and UDIMM	48 x DDR3 RDIMM and LRDIMM
Hard drive bays (hot plug)	2 x 2.5"	4 x 2.5"
Embedded NIC	4 x 1GbE LOM	2 Dual Port Select Network Adapters: 3 options of 4 x 10GbE
RAID controller	PERC H200, H700	PERC H310, H710, H710P
Express Flash drives	Not supported	Up to 2
I/O slots	4 PCIe 2.0 x8 mezz card slots	4 x PCIe 3.0 x8 mezz card slots
Optional SD port	Yes	Yes (redundant hypervisor with vFlash media)



Feature	PowerEdge M910	PowerEdge M820
Dell OpenManage Systems Management	Dell OpenManage Lifecycle Controller 1.x iDRAC6 (Express or Enterprise) with Lifecycle Controller 1.x, CMC 3.x	OpenManage Essentials OMSA Agent OpenManage Power Center (requires iDRAC7 Enterprise with Lifecycle Controller) OpenManage Integrations and Connections iDRAC7 Express for Blades with Lifecycle Controller (standard option)

Specifications

Table 3 lists the technical specifications for the PowerEdge M820 blade server. For the latest information on supported features, visit Dell.com/PowerEdge.

Table 3. Technical specifications

Feature	Technical specification
Form factor; enclosure	Full-height blade; Dell PowerEdge M1000e Blade Enclosure
Processors	Intel Xeon processor E5-4600 product family
Internal interconnect	Intel QuickPath Interconnect (QPI): 6.4GT/s, 7.2GT/s, 8.0GT/s
Cache	2.5MB per core; core options: 4, 6, 8
Memory¹	Up to 1.5TB (48 DIMM slots): 4GB/8GB/16GB/32GB DDR3 up to 1600MT/s
Chipset	Intel C602
Video	Integrated Matrox [®] G200
Primary storage	Hot-plug hard drive options: Up to four 2.5" SAS, SSD, or up to two Express Flash PCIe SSD External storage: For information about Dell external storage options, visit Dell.com/Storage
USB ports	3 front



Feature	Technical specification
I/O mezzanine card options	<p>1Gb/10Gb adapters: Broadcom[®] 5719 quad-port 1Gb Intel I350 quad-port 1Gb Broadcom 57810S-k dual-port 10Gb Intel X520-x/k dual-port 10Gb QLogic[®] QME8262-k dual-port 10Gb Brocade[®] BR1741M-k dual-port 10Gb Mellanox[®] ConnectX[®]-3 dual-port 10GbE KR blade</p> <p>Fibre channel: QLogic QME2662 dual-port 16Gb Emulex[®] LPm16002B-D dual-port 16Gb QLogic QME2572 dual-port 8Gb Emulex LPe1205-M dual-port 8Gb</p> <p>InfiniBand™: Mellanox ConnectX-3 dual port FDR10 40Gb</p>
I/O slots	Fully populated mezzanine card slots and switch modules yield 3 redundant I/O fabrics per blade.
Dell Select Network Adapter (network daughtercard)	2 x 10GbE Broadcom 57810S-k 2P 2 x 10GbE Intel X520-k 2P 2 x 10GbE QLogic QMD8262-k 2P
RAID controller	<p>Internal controllers: PERC H310 PERC H710 PERC H710P</p>
Powersupplies and fans	Supplied by M1000e blade enclosure
Dell OpenManage Systems Management (Agent-free or with OpenManage Server Administrator [OMSA] Agent)	<ul style="list-style-type: none"> • OpenManage Essentials • OMSA Agent • OpenManage Power Center (requires iDRAC7 Enterprise with Lifecycle Controller) • CMC 4.x (available with the M1000e Modular Blade Enclosure) • OpenManage Integrations and Connections: <ul style="list-style-type: none"> — OpenManage Integration Suite for Microsoft[®] System Center — OpenManage Integration for VMware vCenter™ — Connections for HP[®] Operations Manager, IBM[®] Tivoli[®] Netcool[®] and CA Network and Systems Management • iDRAC7 Express for Blades with Lifecycle Controller (standard option) <ul style="list-style-type: none"> — Upgrade to iDRAC7 Enterprise with Lifecycle Controller — Upgrade to 8GB vFlash media or 16GB vFlash media for iDRAC7 Enterprise with Lifecycle Controller — Trial evaluation available for iDRAC7 Enterprise with Lifecycle Controller



Feature	Technical specification
	Microsoft Windows Server [®] 2012 Microsoft Windows Server 2012 R2 (includes Hyper-V [®]) Microsoft Windows Server 2008 R2 SP1, x64 (includes Hyper-V) Novell [®] SUSE [®] Linux [®] Enterprise Server Red Hat [®] Enterprise Linux
Operating systems	Virtualization options: Citrix [®] XenServer [®] Red Hat Enterprise Virtualization [®] VMware vSphere including ESXi For more information on the specific versions and additions, visit Dell.com/OSsupport .

Embedded hypervisor	Two internal SD cards dedicated for hypervisor One dedicated for vFlash media support
----------------------------	--

For more information about the Dell blade solution, see the [PowerEdge M1000e Technical Guide](#) or the [PowerEdge M1000e Blade Chassis Spec Sheet](#).

¹GB means 1 billion bytes and TB equals 1 trillion bytes; actual capacity varies with preloaded material and operating environment and will be less



3 Module views and features

The Dell PowerEdge M820 implements a new module design that supports up to 48 DIMMS and four processors. The M820 is a full-height blade server that requires a PowerEdge M1000e chassis to operate. It occupies one slot vertically in the M1000e for a maximum of eight blade servers in one M1000e chassis. The M820 can be mixed with other existing Dell blades of quarter-height, half-height and full-height form factors.

The following sections provide external and internal views of the system and describe the module features. For more detailed information on features and descriptions for the M820, see the *Dell PowerEdge M820 Systems Owner's Manual* on Dell.com/Support/Manuals.

Module views

Figure 1 shows that the M820 module supports up to four front-accessible, hot-plug hard drives and three USB ports.

Figure 1. M820 front view



The chassis design of the M820 is optimized for easy access to components and for airflow for effective and efficient cooling. Figure 2 shows the M1000e chassis enclosure populated with M820 modules.

Figure 2. M1000e chassis enclosure with M820 blades



The M820 module shown in Figure 3 supports up to 48 DIMMS, four processors and many other features that are described in this guide.



Figure 3. M820 internal module view

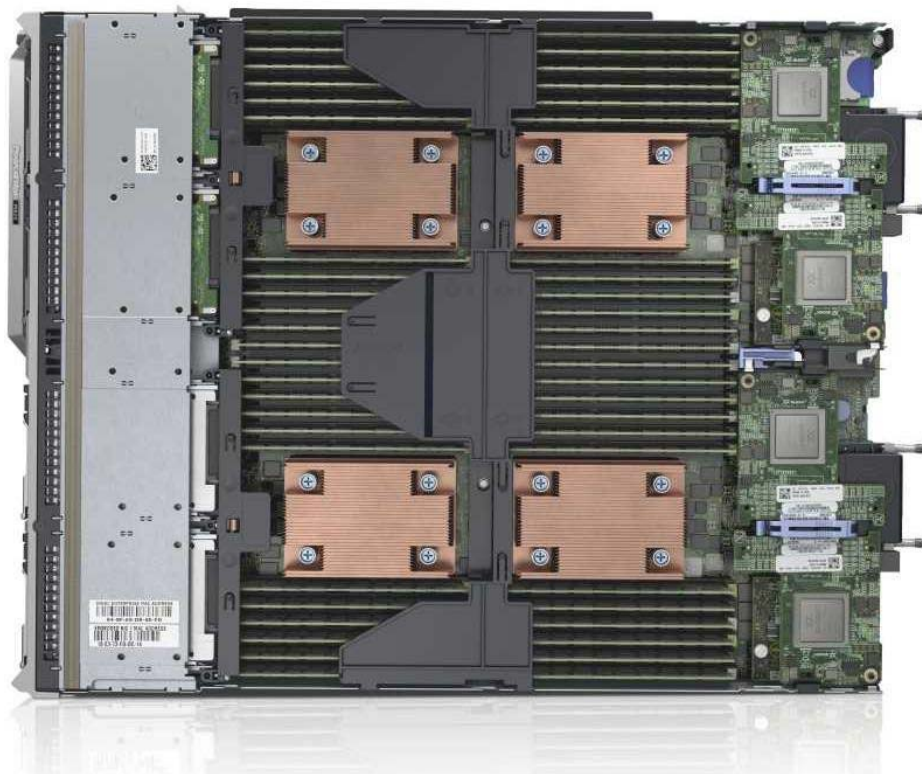

For additional system views, see the *Dell PowerEdge M820 Systems Owner's Manual* on Dell.com/Support/Manuals.

Module features

Table 4 lists the modules features for the M820 system. For additional information on these features, see the *Dell PowerEdge M820 Systems Owner's Manual* on Dell.com/Support/Manuals.

Table 4. Module features

Feature	Description
USB connectors	3 front-accessible USB connectors
Status indicator	Indicator for M820 power status
Hard drives	4 front-accessible, hot-plug, 2.5-inch drives; see the Storage section for details
Hard drive activity LEDs	Indicate the status and activity
Blade handle release button	Release button on the front handle of the blade server
USB key	Internal USB connector for a USB flash memory key that can be used as a boot device, security key or mass storage device
Trusted Platform Module (TPM)	TPM is used to generate/store keys, protect/authenticate passwords and create/store digital certificates; it also supports the Intel Xeon TXT functionality.



Feature	Description
Quick Resource Locator (QRL)	This code on the chassis can be scanned by a smartphone application to access additional information and resources for the server, including videos, reference materials, service tag information and Dell contact information.

LCD control panel

The M1000e chassis enclosure LCD control panel is located on the front of the M1000e chassis to provide user access to buttons, display and I/O interfaces. For more information on the M1000e LCD control panel, see the *Dell PowerEdge Modular Systems Hardware Owner's Manual* on Dell.com/Support/Manuals.

Quick Resource Locator

Dell PowerEdge 12th-generation servers feature a Quick Resource Locator (QRL) — a model-specific Quick Response (QR) code that is located on the server (see Figure 4). Use your smartphone to access the Dell QRL application to learn more about the server.

Figure 4. QRL code located on module

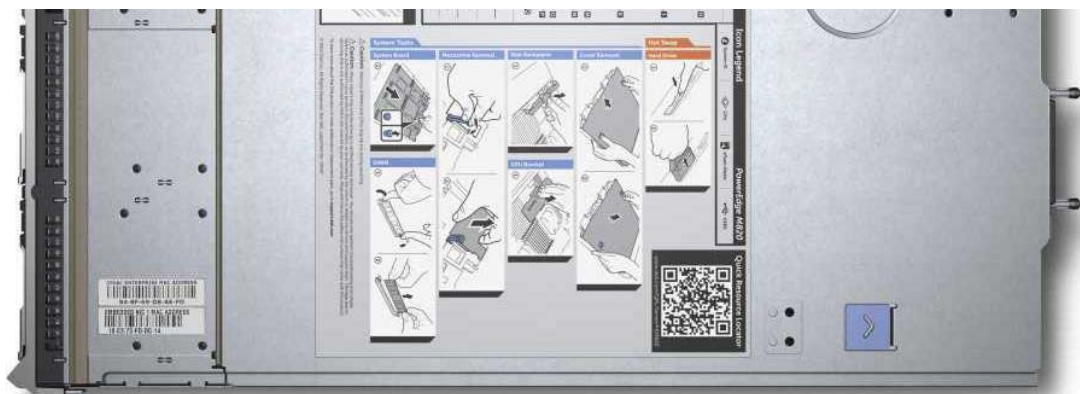

This QRL code allows you to:

- View step-by-step videos, including overviews of system internals and externals, as well as detailed, concise, task-oriented videos and installation wizards
- Locate reference materials, including searchable owner's manual content, LCD diagnostics and an electrical overview
- Look up your service tag so you can quickly gain access to your specific hardware configuration info and warranty information
- Contact Dell directly (by link) to get in touch with technical support and sales teams and provide feedback to Dell

These codes provide an easy way to retrieve the critical support information you need when you need it, making you more efficient and effective in managing your hardware.

For more information on the M1000e chassis enclosure features, see the *Dell PowerEdge Modular Systems Hardware Owner's Manual* on Dell.com/Support/Manuals.



4 Processors

The Dell PowerEdge M820 features the Intel Xeon processor E5-4600 product family, which offer an ideal combination of performance, power efficiency and cost. These processors provide high performance no matter what your constraint is — floor space, power or budget — and excel on workloads that range from the most complicated scientific exploration to crucial web-serving and infrastructure applications. In addition to providing raw performance gains, Intel's integrated I/O, reduces latency by adding more lanes and doubling bandwidth. This helps to reduce network and storage bottlenecks, unleashing the processor's performance capabilities.

Processor features

The new Intel Xeon processor E5-4600 product family adds new features and improves upon many features of the predecessor Intel Xeon processor series. A summary of what's new and improved includes:

- Up to two additional cores and up to 8MB more last level cache
- More memory — 16 more DIMMs than previous-generation of full-height blade servers with support for up to 32GB DIMMs, increasing memory capacity up to 1.5TB
- Intel Integrated I/O support for up to 80 lanes of PCIe 3.0, which can reduce latency
- Faster connections provided throughout the system with support for DDR3 1600MT/s memory and 8.0GT/s QPI
- Intel Data Direct I/O (DDIO) allowing I/O traffic to skip the main system memory and be directed straight to the processor cache, which can provide a significant reduction in latency as well as allowing memory to remain in a low-power state
- Intel Advanced Vector Extensions offering up to double the floating point operations per clock cycle by doubling the length of registers, which can be useful for addressing very complex problems or dealing with large-number calculations that are integral to many technical, financial and scientific computing problems
- Intel Turbo Boost Technology 2.0 delivering up to double the boost of the previous-generation turbo technology
- Continued improvements to both Intel TXT and AES-NI helping to better protect systems and data

For more information on the Intel Xeon processor E5-4600 product family, visit Intel.com.



Supported processors

The M820 supports up to four processors with up to eight cores per processor. Table 5 lists the Intel Xeon processors supported by the PowerEdge M820. For the latest information on supported processors, visit Dell.com/PowerEdge.

Table 5. Supported processors

Model	Speed	TDP	Cache	Cores/threads	QPI	Turbo	MaxMemory Speed
XeonE5-4650	2.7GHz	130W	20MB	8/16	8.0GT/s	Yes	1600
XeonE5-4650L	2.6GHz	115W	20MB	8/16	8.0GT/s	Yes	1600
XeonE5-4640	2.4GHz	95W	20MB	8/16	8.0GT/s	Yes	1600
XeonE5-4620	2.2GHz	95W	16MB	8/16	7.2GT/s	Yes	1333
XeonE5-4617	2.9GHz	130W	15MB	6/6	7.2GT/s	Yes	1600
XeonE5-4610	2.4GHz	95W	15MB	6/12	7.2GT/s	Yes	1333
XeonE5-4607	2.2GHz	95W	12MB	6/12	6.4GT/s	NA	1066
XeonE5-4603	2.0GHz	95W	10MB	4/8	6.4GT/s	NA	1066

For information on processor installation and configuration, see the *Dell PowerEdge M820 Systems Owner's Manual* on Dell.com/Support/Manuals.

Chipset

The Intel C602 chipset is implemented on the PowerEdge M820. For more information, visit Intel.com.



5 Memory

More memory options are available than ever before with the Dell PowerEdge M820 — greater capacities, higher frequencies and more flexibility. The M820 supports up to 1.5TB of memory and speeds up to 1600MT/s, providing high performance in a variety of applications. High memory density means there is no compromise when it comes to virtualization.

Increase your uptime and reduce data loss due to Dell's focus on reliability, availability and serviceability (RAS) features. RAS aids in the rapid and accurate diagnosis of faults that require service, increasing your memory reliability. System uptime is reinforced with RAS features like memory mirroring, sparing and many others.

In addition to supporting existing RDIMM technologies, the M820 supports load reduced DIMMs (LRDIMMs), which use a buffer to reduce memory loading and allow for greater density, allowing for the maximum platform memory capacity.

Supported memory

Table 6 lists the memory technologies supported by the M820.

Table 6. Memory technologies supported

Feature	RDIMM	LRDIMM
Register	Yes	Yes
Buffer	No	Yes
Frequencies*	800, 1066, 1333 or 1600MT/s	1066 or 1333MT/s
Ranks supported	1, 2 or 4	4
Capacity per DIMM	4, 8, 16 or 32GB	32GB
Maximum DIMMs per channel	3	3
DRAM technology	x4 or x8	x4
Temperature sensor	Yes	Yes
Error Correction Code (ECC)	Yes	Yes
Single Device Disable Code (SDDC)	Yes	Yes
Address parity	Yes	Yes

*Although the M820 supports DIMM speeds of 800MT/s and 1066MT/s, you can only purchase this system with DIMM speeds of 1333MT/s and 1600MT/s on Dell.com/PowerEdge.



Table 7 lists the DIMMs that are supported on the M820. For the latest information on supported memory, visit Dell.com/PowerEdge.

Table 7. DIMMs supported

Capacity (GB)	Speed (MT/s)		DIMM	Data width		
2	1600	RDIMM	1	x8	Advanced ECC	1.35
2	1333	RDIMM	1	x8	Advanced ECC	1.35
4	1333	RDIMM	2	x8	Advanced ECC	1.35
4	1600	RDIMM	2	x8	Advanced ECC	1.35
4	1333	RDIMM	1	x4	All modes	1.35
4	1333	RDIMM	2	x8	Advanced ECC	1.35
8	1333	RDIMM	2	x4	All modes	1.35
8	1333	RDIMM	2	x4	All modes	1.35
8	1600	RDIMM	2	x4	All modes	1.35
16	1600	RDIMM	2	x4	All modes	1.35
16	1333	RDIMM	2	x4	All modes	1.35
32	1333	LRDIMM	4	x4	All modes	1.35
32	1333	RDIMM	4	x4	All modes	1.35

Memory configurations

The M820 server supports flexible memory configurations ranging from capacities of 4GB to 1.5TB, and up to 12 DIMMs per processor (up to 48 DIMMs in a four-processor configuration). Each processor has four memory channels, with each channel supporting up to three DIMMs.

Flexible memory configuration

The M820 supports a flexible memory configuration according to the following basic rules:

- Speed: If DIMMs of different speeds are mixed, all channels across all processors operate at the slowest DIMM's common frequency.
- DIMM type: Only one type of DIMM is allowed per system: RDIMM or LRDIMM. These types cannot be mixed.

The following additional memory population guidelines apply to the M820:

- Up to two quad-rank (QR) DIMMs and up to three dual-rank (DR) or single-rank (SR) DIMMs may be populated per channel. Although an LRDIMM is physically a QR DIMM, logic on the LRDIMM can make it appear as a DR DIMM to the system, allowing up to three LDRIMMs per channel.
- DIMMs must be installed in each channel, starting with the DIMM farthest from the processor.
- DIMMs should be installed with largest rank count to smallest. For example, if DR DIMMS are mixed with SR DIMMS, DR DIMMS should be placed in the lowest DIMM slots, followed by the SR DIMMS.

For more information on memory configuration and population, see the *Dell PowerEdge M820 Systems Owner's Manual* on Dell.com/Support/Manuals.



Memory speed

The M820 server supports memory speeds of 1600MT/s, 1333MT/s, 1066MT/s and 800MT/s, depending on the DIMM types installed and the configuration. All memory on all processors and channels run at the same speed and voltage. By default, the system runs at the highest speed for the channel with the lowest DIMM voltage and speed. The operating speed of the memory is also determined by the maximum speed supported by the processor, the speed settings in the BIOS and the operating voltage of the system.

Table 8 lists the memory configuration and performance details for the M820, based on the population of the number and type of DIMMs per memory channel.

Table 8. Memory speed capabilities

DIMM type	DIMM 0	DIMM 1	DIMM 2	Number of DIMMs	Speed (MT/s)			
					800*	1066*	1333	1600
RDIMM	SR			1	∞	∞	∞	∞
	DR			1	∞	∞	∞	∞
	QR			1	∞	∞	∞	
	SR	SR		2	∞	∞	∞	∞
	SR	DR		2	∞	∞	∞	∞
	DR	DR		2	∞	∞	∞	∞
	QR	SR		2	∞	∞		
	QR	DR		2	∞	∞		
	QR	QR		2	∞	∞		
	SR	SR	SR	3	∞	∞	∞	
	SR	SR	DR	3	∞	∞	∞	
	SR	DR	DR	3	∞	∞	∞	
	DR	DR	DR	3	∞	∞	∞	
LRDIMM	QR			1		∞	∞	
	QR	QR		2		∞	∞	
	QR	QR	QR	3		∞	∞	

*Although the M820 supports DIMM speeds of 800MT/s and 1066MT/s, you can only purchase this system with DIMM speeds of 1333MT/s and 1600MT/s on Dell.com/PowerEdge.

Memory RAS features

RAS features help keep the system online and operational without significant impact to performance, and can decrease data loss and crashing due to errors. RAS aids in rapid, accurate diagnosis of faults that require service. Table 9 describes the memory RAS features supported on the M820.



Table 9. Memory RAS features

Feature	Description
Dense configuration optimized profile	Increased memory reliability can be a result from this selectable platform profile that adjusts parameters to reduce faults regarding refresh rates, speed, temperature and voltage.
Memory demand and patrol scrubbing	Demand scrubbing is the ability to write corrected data back to the memory once a correctable error is detected on a read transaction. Patrol scrubbing proactively searches the system memory, repairing correctable errors.
Recovery from single DRAM device failure (SDDC)	Recovery from Single DRAM Device Failure (SDDC) provides error checking and correction that protects against any single memory chip failure as well as multi-bit errors from any portion of a single memory chip.
Failed DIMM isolation	This feature provides the ability to identify a specific failing DIMM channel pair, thereby enabling the user to replace only the failed DIMM pair.
Memory mirroring: intra-socket	Memory mirroring is a method of keeping a duplicate (secondary or mirrored) copy of the contents of memory as a redundant backup for use if the primary memory fails. The mirrored copy of the memory is stored in memory of the same processor socket.
Memory address parity protection	This feature provides the ability to detect transient errors on the address lines of the DDR channel.
Memory sparing (rank)	Memory sparing allocates one rank per channel as a spare. If excessive correctable errors occur in a rank or channel, they are moved to the spare area while the operating system is running to prevent the errors from causing an uncorrectable failure.
Memory thermal throttling	This feature helps to optimize power/performance and can also be used to prevent DIMMs from overheating.

For information on memory mirroring and sparing configurations, see the *Dell PowerEdge M820 Systems Owner's Manual* on Dell.com/Support/Manuals. Memory RAID is not supported.



6 Storage

The Dell PowerEdge M820 provides comprehensive internal storage options, including several drive types and storage controllers to choose from.

Express Flash PCIe SSD is a new option that can provide vastly accelerated performance over previous technologies. Dell Express Flash drives use PCIe lanes to connect directly to the processor and chipset and are easily accessible by hot-plug drive bay.

Internal storage

The M820 is available in three different hard-drive backplane options. Table 10 lists the options for backplanes, hard-drive controllers and drive types for the M820.

Table 10. Hard-drive backplane options

Number of drives	Drive types	Backplane	Controller
4	SAS HDD	SAS	MiniPERC card
4	SAS HDD, Express Flash PCIe SSD	SAS (2) PCIe SSD (2)	MiniPERC card, PCIe extender
2	SAS HDD	SAS	MiniPERC card

Supported hard drives

The M820 supports up to four 2.5-inch SAS or two 2.5-inch PCIe SSDs and shown in Table 11. For the latest information on supported hard drives, visit Dell.com/PowerEdge.

Table 11. Supported hard drives

Form factor	Type	Speed (rpm)	Capacities
2.5"	Nearline SAS (6Gb)	7.2K	500GB, 1TB, 1TB self-encrypting drive (SED)
	SAS (6Gb)	10K	300GB, 600GB, 900GB, 900GB SED, 1.2TB
	SAS (6Gb)	15K	146GB, 300GB, 300GB SED
	SAS SSD (SLC, 6Gb)	N/A	200GB, 400GB
	SATA ¹ SSD (eMLC, 3Gb)	N/A	100GB, 200GB, 400GB
	Express Flash PCIe SSD (SLC)	N/A	175GB, 350GB

¹Supports SATA hard drives through the SAS backplane.



Express Flash drives

Express Flash drives use PCIe and SSD technologies to provide performance, scalability and optimal serviceability. Accelerated performance with high IOPs is made possible without requiring processor resources or capturing DRAM. Also, Express Flash drives use a standardized, 2.5-inch hot-plug form factor, which allows a common management process for all drives.

The PowerEdge M820 has an option to support up to two Express Flash PCIe SSD drives with the PCIe SSD backplane configuration. This backplane configuration may be selected at purchase, but may not be upgraded later.

Storage controllers

Dell provides highly capable RAID options for you to ensure that your data remains safe. Dell's RAID controller options offer impressive performance improvements. The internal RAID controllers have a dedicated connection to the system board.

Supported RAID controllers

The newest line of PowerEdge RAID Controllers (PERCs) offers high I/O performance for a variety of uses, including database applications and streaming digital media environments.

PERC H710P

The PERC H710P is an eight-port, internal, 6Gbps PCIe RAID controller (mini form factor) with 1GB DDR3 non-volatile (NV) cache.

PERC H710

The PERC H710 is an eight-port, internal, 6Gbps PCIe RAID controller (mini form factor) with 512MB DDR3 NV cache.

PERC H310

The PERC H310 is an eight-port, internal, 6Gbps PCIe RAID controller (mini form factor) that is a low-cost, entry-level RAID solution.

For more information about the latest PERC offerings, see Dell.com/PERC.

RAID controller feature support

Table 12 lists the features supported by the RAID controller options on the M820.

Table 12. RAID controller feature support

Feature	PERC option		
	H310	H710	H710P
Software RAID stack			
iMR firmware stack	✓		
MR firmware stack		✓	✓
SSD support	✓	✓	✓
SATA backplane			
SAS backplane	✓	✓	✓
SATA hard drives	✓ ¹	✓ ¹	✓ ¹



Feature	PERC option		
	H310	H710	H710P
SAS hard drives	✓	✓	✓
Un-configured hard drive support (non-RAID)	✓		
RAID 0	✓	✓	✓
RAID 1	✓	✓	✓
DDR3 cache (512MB)		✓	
DDR3 cache (512MB)			✓
Non-volatile cache option		✓	✓
Microsoft Windows® support	✓	✓	✓
Linux support	✓	✓	✓
Virtualization support	✓	✓	✓
Mini form factor	✓	✓	✓
Embedded on motherboard	N/A	N/A	N/A
PCIe 2.0	✓	✓	✓
Local support for self-encrypting drive (SED)	X		✓
UEFI browser	✓	✓	✓
HII	✓	✓	✓

¹Supports SATA hard drives through the SAS backplane.



7 Networking and mezzanine cards

The Dell PowerEdge M820 offers balanced, scalable I/O capabilities, including integrated PCIe 3.0 capable mezzanine card slots. Dell Select Network Adapters, Dell's network daughtercards, let you choose the right network fabric without using up a valuable mezzanine card slot. Pick the speed, technology, vendor and other options such as switch independent partitioning, which let you share and manage bandwidth on 10GbE connections.

Installation of mezzanine cards requires an M1000e I/O module (IOM) of the same fabric technology to be installed in the corresponding fabric slot of the mezzanine to support data flow through that fabric or slot.

Select Network Adapters

The Select Network Adapter family is purpose-built and includes flexible LAN on motherboard (LOM) card options for Dell PowerEdge 12th-generation servers. The Select Network Adapter form factor delivers the value of LOM integration with the system, including BIOS integration and shared port for manageability while providing the flexibility of a modular card.

The PowerEdge M820 supports two custom network daughtercards (NDC), as part of Select Network Adapters family, to house the complete LOM subsystem. There are two form factors of Select Network Adapters — one for blade servers and one for rack servers. The blade network daughtercard options supported on the M820 provide dual-port 10GbE interfaces.

Figure 5. Blade network daughtercard

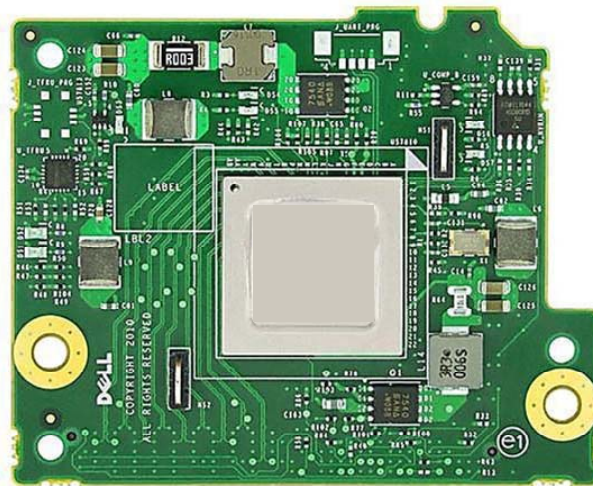

Table 13 lists the available Select Network Adapter options and their supported features for the M820.

Table 13. Supported Select Network Adapter options and features

Features	Broadcom 57810S-k	Intel X520-k	QLogic QMD8262-k
Ports x link speed	2x10Gb	2x10Gb	2x10Gb
Supported speed	1Gb and 10Gb	1Gb and 10Gb	10Gb only
SR-IOV	Not supported	Supported	Not supported
ISCSIHBA	Supported ¹	Not supported	Supported
FCoE	Supported ²	Supported ²	Supported
Switch independent partitioning	Supported ³	Not supported	Supported
DCB	Supported ²	Supported ⁴	Supported
DCB with iSCSI TLV	Supported ⁵	Supported ⁵	Supported

¹Only 10Gb ports have iSCSI HBA support.

²Only 10Gb ports have FCoE support.

³Only 10Gb ports have switch independent partitioning support. The maximum number of partitions supported is eight (four partitions per 10GE port).

⁴Only 10Gb ports have DCB support.

⁵Only 10Gb ports have iSCSI TLV support.

System management integration

With M820, the job of deploying, updating, monitoring and maintaining the Select Network Adapters is fast and easy. System management integration features include the following:

- Pre-boot: Using the Dell Lifecycle Controller graphical user interface (GUI) to set configuration such as bandwidth allocation or firmware revision level
- Post-boot: Agent-free out-of-band or high-speed in-band connection over LOM through the Operating System/BMC pass-through feature for sensory information
- Automation of firmware and driver version deployment upon component replacement
- Automatic monitoring of NIC status and notification on SNMP traps
- Local or remote re-configuration of any NIC, physical or virtual
- PXE boot enabled on all LOM and NDCs for ease of use
- Boot from SAN (iSCSI, FCoE) configuration for networking devices through the Lifecycle Controller GUI



Mezzanine cards

The M820 provides four PCIe 3.0 mezzanine connectors for add-in cards. The M820 has been designed to be PCIe 3.0 compliant in order to take full advantage of the processor capabilities.

Table 14 lists the supported mezzanine cards for the M820.

Table 14. Supported mezzanine cards

Type	Adapter
1Gb/10Gb NICs	Broadcom 5719 quad-port 1Gb
	Intel I350 quad-port 1Gb
	Broadcom 57810S-k dual-port 10Gb
	Intel X520-x/k dual-port 10Gb
	QLogic QME8262-k dual-port 10Gb
	Brocade BR1741M-k dual-port 10Gb
	Mellanox ConnectX-3 dual-port 10GbE KR blade
Fibre channel	QLogic QME2572 dual-port 8Gb
	Emulex LPe1205-M dual-port 8GB
	QLogic QME2662 dual-port 16Gb
	Emulex LPm16002B-D dual-port 16Gb
InfiniBand	Mellanox ConnectX-3 dual-port FDR10 40Gb

For the latest information on supported mezzanine cards for the M820, visit Dell.com/PowerEdge.



8 Power, thermal and acoustics

Lower overall system-level power draw is a result of Dell's breakthrough system design. The PowerEdge M820 blade server and M1000e chassis enclosure maximize performance per watt through a combination of power and cooling, energy-efficient technologies, and tools. Additionally, the M820 has an extensive collection of sensors that automatically track thermal activity, which helps regulate temperature thereby reducing server noise and power consumption.

Power consumption and energy efficiency

With the rise in the cost of energy coupled with increasing data center density, Dell provides tools and technologies to help you realize greater performance with less energy cost and waste. More efficient data center usage can reduce costs by slowing the need for additional data center space. Table 15 lists the tools and technologies Dell offers to help you achieve your data center goals by lowering power consumption and increasing energy efficiency.

Table 15. Power tools and technologies

Feature	Description
Power supply units (PSU) portfolio	Dell's PSU portfolio includes intelligent features such as dynamically optimizing efficiency while maintaining availability and redundancy.
Tools for right-sizing	Energy Smart Solution Advisor (ESSA) is a tool that helps you determine the most efficient configuration possible. With Dell's ESSA, you can calculate the power consumption of your hardware, power infrastructure and storage. ESSA can help you determine exactly how much power your server will use at a given workload, and the PSU Advisor can help you choose the best, most efficient PSU for your workload. Learn more at Dell.com/ESSA .
Industry compliance	Dell's servers are compliant with all relevant industry certifications and guidelines, including 80 PLUS, Climate Savers and ENERGY STAR.
Power monitoring accuracy	PSU power monitoring improvements include: <ul style="list-style-type: none"> • Monitoring accuracy is currently 1%, whereas the industry standard is 5% • More accurate reporting of power • Better performance under a power cap
Power capping	Use Dell's systems management to set the power cap limit for your systems to limit the output of a PSU and reduce system power consumption. Dell is the first hardware vendor to leverage Intel Node Manager for circuit-breaker fast capping.
Systems management	iDRAC7 Enterprise provides server-level management that monitors, reports and controls power consumption at the processor, memory and system level. Dell OpenManage Power Center delivers group power management at the rack, row and data center level for servers, power distribution units and uninterruptible power supplies.
Active power management	Intel Node Manager is an embedded technology that provides individual server-level power reporting and power limiting functionality. Dell offers a complete power management solution comprised of Intel Node Manager



Feature	Description
	<p>accessed through Dell iDRAC7 Enterprise and OpenManage Power Center that allows policy-based management of power and thermals at the individual server, rack and data center level.</p> <p>Hot spare reduces power consumption of redundant power supplies.</p> <p>Thermal control of fan speed optimizes the thermal settings for your environment to reduce fan consumption and lower system power consumption.</p> <p>Idle power enables Dell servers to run as efficiently when idle as when at full workload.</p>
Dell Fresh Air cooling	<p>With the thermal design and reliability of Dell products, certain configurations have the capability to operate at excursion-based temperatures beyond the industry standard of 35°C (95°F) up to 45°C (113°F) for excursionary periods of time and up to a 26°C dew point at 90% relative humidity without impacting your availability model. Find additional information at Dell.com/FreshAir.</p>
Rack infrastructure	<p>Dell offers some of the industry's highest efficiency power infrastructure solutions, including:</p> <ul style="list-style-type: none"> • Power distribution units • Uninterruptible power supplies • Energy Smart containment rack enclosures <p>Find additional information at Dell.com/RackInfrastructure.</p>

Find additional information at Dell.com/PowerAndCooling and Dell.com/PowerCenter.

Power supply units

The M1000e chassis enclosure provides power and cooling for the M820 blade server. For information on the M1000e power supply units, see the *PowerEdge M1000e Technical Guide* on Dell.com/PowerEdge.

Thermal and acoustics

Optimized thermal management keeps fan speeds in the PowerEdge M820 as low as possible, contributing to quiet operation and ensuring proper component cooling.

Thermal design

The thermal design of the PowerEdge M820 reflects the following:

- **Comprehensive thermal management:** The PowerEdge M820 dynamically controls system cooling fan speed, based on responses from critical sensors that monitor the temperature of several components, including:
 - Processors
 - DIMMs
 - System inlet ambient
 - Mezzanine card
 - NDC

Thermal control also detects and responds to hardware configuration. Thermal management adjusts cooling according to what the system really needs, and draws lower fan power draw and generates lower acoustical noise levels than those without such controls.



- **Environmental specifications:** The optimized thermal management makes the PowerEdge M820 reliable under a wide range of operating environments as shown in Table 24.

Acoustical performance

The acoustical performance of the PowerEdge M820 is reflected in Table 16. The addition of some components can cause an increase in fan speed and acoustical output. Contributors to acoustical output can include:

- The system thermal profile selected in BIOS (for example, Power optimized DAPC or Performance optimized)
- NDC
- Number of installed processors
- Population of modular, non-homogenous modular deployment
- Impedance of blanks

Table 16. M820 acoustical performance

Configuration (23 ± 2°C ambient)	CPUs	Hard drives	DIMMs	HDD controller	NDC	PCI cards	Operating mode	L _{WA-UL} ¹ (bels)	L _{pA} ² (dBA)
Minimum	2 x 95W (6 core)	1 x 2.5" SATA (7.2K)	2 x 2GB	PERC H310 (mini)	None	Any mezz. card	Standby ³	6.9	51
							Idle ⁴	7.4	55
Typical	2 x 95W (8 core)	2 x 2.5" SAS (10K)	16 x 8GB	PERC H710 (mini)	1Gb	Any mezz. card	Standby ³	6.9	52
							Idle ⁴	7.3	55

¹L_{WA-UL} is the upper limit sound power levels (L_{WA}) calculated per section 4.4.1 of ISO 9296 (1988) and measured in accordance to ISO 7779 (2010).

²L_{pA} is the average A-weighted sound pressure level of four bystanders in accordance with ISO 7779 (2010) Section 8.6.2. The system is placed inside 42U rack in 25 cm height.

³Standby: AC Power is connected to power supply units but the system is not turned on.

⁴Idle: Reference ISO 7779 (2010) definition 3.1.7; system is running in its operating system but no other specific activity.

Note: Stress is an operating mode per ISO 7779 (2010) definition 3.1.6. Since blade stressing applications vary widely, blade stress values are not available.



9 Operating systems and virtualization

The Dell PowerEdge M820 supports a wide range of industry-standard operating systems and virtualization software.

Supported operating systems

Table 17 lists the operating systems supported on the M820. For the latest information on supported operating systems, see Dell.com/OSsupport.

Table 17. Primary operating system support

Operating System	Platform	Edition
Red Hat Enterprise Linux 5.8¹	x32 x64	N/A
Red Hat Enterprise Linux 6.3²	x64	N/A
Red Hat Enterprise Linux 6.3² for HPC Compute Node	x64	N/A
SUSE Linux Enterprise Server 11 SP3	x64	N/A
SUSE Linux Enterprise Server 10 SP4	x64	N/A
Microsoft Windows Server 2012	x64	Standard Data center
Microsoft Windows Server 2012 R2	x64 (with Microsoft Hyper-V role enabled)	Standard Enterprise Data center
Microsoft Windows Server 2008 R2 with SP1	x64 (with Microsoft Hyper-V role enabled)	Web Standard Enterprise Data center HPC Foundation

¹RHEL 5.7 is the minimum supported version. Current drop in box option is RHEL 5.8.

²RHEL 6.1 is the minimum supported version. Current factory install is RHEL 6.3.

Support of the operating systems listed in Table 18 is limited to a virtual environment as a guest operating system. Please contact the software vendor for additional support or questions about running the operating system in a virtualized environment.

Table 18. Virtual guest operating system support

Operating System	Platform	Edition
Microsoft Windows 2003	x86	Web



Operating System	Platform	Edition
Microsoft Windows 2003 R2 with SP2	x86	Standard Enterprise
	x64	Standard Enterprise Data center

Supported virtualization

One of the key features for virtualization on the M820 is the support for a failsafe hypervisor. By running the hypervisor on an optional SD card and installing a backup copy on the other mirrored SD card, you can protect against hardware failure and maximize virtualization uptime. Table 19 highlights the virtualization support for the M820.

Table 19. Virtualization support

Operating systems	Install version	Factory options	Internal dual SD module install support	
VMware	vSphere v5.0	ESXi	DIB	Yes
	vSphere v5.0 U1	ESXi	FI/DIB	Yes
	vSphere v5.1	ESXi	FI/DIB	Yes
Citrix	XenServer v6.1	N/A	DIB	No
Red Hat ²	Enterprise Virtualization v3.1	N/A	DIB	No

FI = factory install; DIB = drop-in-box

²No OpenManage support; drop-in-box license registration card only



10 Dell OpenManage systems management

Whether your IT environment consists of a few servers or a few thousand servers, Dell OpenManage systems management solutions provide comprehensive management for evolving IT environments. OpenManage is based on open standards and provides agent-based and agent-free server lifecycle management functionality for Dell PowerEdge servers. OpenManage solutions help you automate and streamline essential hardware management tasks.

The advanced management capabilities of Dell OpenManage also integrate into offerings from other popular systems management solutions that you may already use, making Dell platforms easy to manage and deploy in any IT environment. This ensures your IT services are available when your business needs them. If you have already standardized on offerings from industry leaders, such as BMC Software, Microsoft, Symantec™, VMware or other vendors, you can leverage OpenManage integration and connections developed for use with your existing systems management framework to efficiently manage Dell servers, storage, business-client PCs and network devices.

Start with a firm foundation for efficient hardware management using OpenManage tools, utilities and management consoles. OpenManage systems management solutions consist of a combination of embedded management features and software products that help you automate and simplify the entire server lifecycle: deploy, update, monitor and maintain. OpenManage solutions are innovatively designed for simplicity and ease of use to help you reduce complexity, save time, achieve efficiency, control costs and empower productivity.

Systems management solutions

Dell systems management solutions include a wide variety of tools, products and services that enable you to leverage an existing systems management framework. As shown in Figure 6, Dell systems management solutions are centered around OpenManage server management, featuring iDRAC with Lifecycle Controller.

Figure 6. Dell systems management solutions



OpenManage systems management

The Dell OpenManage systems management portfolio includes powerful hardware and software management tools and consoles. OpenManage simplifies the lifecycle of deploying, updating, monitoring and maintaining your Dell PowerEdge servers.

iDRAC7 with Lifecycle Controller

The Integrated Dell Remote Access Controller 7 (iDRAC7) with Lifecycle Controller is the heart of the second generation of Dell PowerEdge server embedded management functionality. In addition to enabling agent-free management, iDRAC7 with Lifecycle Controller provides remote access to the system — whether or not there is a functioning operating system running on the server. These embedded features improve all aspects of a typical server lifecycle. Table 20 describes the functions and benefits of iDRAC7 with Lifecycle Controller.

Table 20. iDRAC7 with Lifecycle Controller functions and benefits

Feature	Function	Benefit
Out of band (OOB)	iDRAC7 offers real-time OOB discovery, inventory, deployment monitoring, alerting and updates for servers and internal storage	Manage servers independent of the OS type or status — even if an OS is not installed
Single codebase	All server types have the same embedded management hardware and firmware	Simplified and consistent maintenance across server platforms
Dedicated GbE port (PowerEdge rack and tower systems)	Gigabit Ethernet (GbE) replaces 10/100 on predecessor iDRAC6	Fast throughput for better performance; compatibility with setup for switches
Email alerts	Simplified, more informative and expanded coverage than previous versions of iDRAC	More detail allows IT administrators to be more efficient in diagnosing and remediating an issue; alerts include a direct, embedded URL in the email notification to further speed resolution
vFlash media	Enabled with iDRAC7 Enterprise	Allows for use of a non-Dell SD card
Enhanced power management	Integration with Intel Node Manager provides data center level power monitoring and capping (requires iDRAC7 Enterprise)	Fine tune data center power usage and report on historical power usage by rack, row or room using OpenManage Power Center



Feature	Function	Benefit
Electronic licensing	To obtain a software license key for iDRAC7 Express for Blades or iDRAC7 Enterprise after server purchase, submit a request to purchase a software license key through the Dell Licensing Portal or with a Dell sales representative	If iDRAC7 Express for Blades or iDRAC7 Enterprise is ordered during initial point of sale, license key is installed. If Basic Management is ordered during initial point of sale, customer must request a license key through the Dell Licensing Portal. For most server models, embedded server management and electronic licensing enables feature enhancements that do not require installation of additional hardware or system downtime.

iDRAC7 feature comparison

iDRAC7 Enterprise is available for the PowerEdge M820, and Dell also offers an option of iDRAC7 Express for Blades. A detailed feature comparison for iDRAC7 Enterprise and iDRAC7 Express for Blades is shown in Table 21.

Table 21. Feature comparison for iDRAC7 Enterprise and iDRAC7 Express for Blades

Feature (function)	iDRAC7 Enterprise	iDRAC7 Express for Blades
Local configuration with Lifecycle Controller GUI	∞	∞
IPMI 2.0	∞	∞
Embedded diagnostics	∞	∞
Local OS install	∞	∞
Local updates	∞	∞
Driver pack	∞	∞
Encryption	∞	∞
Dedicated NIC 1Gbps (100MB in iDRAC6)	∞ ¹	∞ ¹
IPv6	∞	∞
Auto-discovery	∞	∞
Auto-recovery	∞	∞
Web GUI	∞	∞
Remote CLI	∞	∞
Local/SSH CLI	∞	∞
Serial redirection	∞	∞
Remote configuration	∞	∞
Remote update	∞	∞
Email alerts	∞	∞



Feature (function)	iDRAC7 Enterprise	iDRAC7 Express for Blades
SNMP alerts	∞	∞
Comprehensive monitoring	∞	∞
Virtual console (4 user)	∞	∞ ²
Virtual media	∞	∞
Crash screen capture ³	∞	∞
Power control	∞	∞
Power monitoring	∞	∞
Virtual console chat	∞	
Support for customer-supplied SD cards for vFlash	∞	
Virtual flash partitions	∞	
Virtual folders	∞	
Remote file share	∞	
Crash video playback	∞	
Boot record/playback	∞	
Part replacement	∞	
Backup and restore configurations	∞	
Power capping	∞	
Enterprise group power management	∞	
Directory services (AD, LDAP)	∞	
PK authentication	∞	
Two-factor authentication ⁴	∞	

¹Blade-to-chassis internal connection is 100MB

²Single user

³Requires OMSA agent on target server

⁴Uses Microsoft ActiveX[®] on Internet Explorer[®] only

Agent-based management

Most systems management solutions require pieces of software, called agents, to be installed on each node in order to be managed within the IT environment. Additionally, the same agent is often used as a local interface into the hardware health and may be accessed remotely as a management interface, typically referred to as a one-to-one interface. For customers that continue to use agent-based solutions, Dell provides OpenManage Server Administrator.

OpenManage Server Administrator

The Dell OpenManage Server Administrator (OMSA) agent gives you a comprehensive, one-to-one systems management solution for both local and remote servers and their storage. OMSA can help simplify single-server monitoring with a secure command-line interface (CLI) or Web-based management GUI. It can also be used to view system configuration, inventory, health and performance.



Agent-free management

Because Dell PowerEdge servers have embedded server lifecycle management, in many cases, there is no need to install an OpenManage systems management software agent into the operating system of a Dell PowerEdge server. This greatly simplifies and streamlines the management footprint.

Chassis Management Controller console for blade systems

The Dell CMC is a systems management hardware and software solution for managing multiple Dell blade chassis. The CMC is a hot-pluggable module inserted in the back of a Dell blade chassis. It provides a secure interface that enables an administrator to inventory, perform configuration and monitoring tasks, remote power on/off blades, and enable alerts for events on servers and components in the blade chassis.

The CMC uses iDRAC7 with Lifecycle Controller to perform management functions, such as opening a remote console session from the CMC interface.

Dell consoles

The central console in a systems management solution is often referred to as the one-to-many console. The central console provides a rapid view and insight into the overall health of all systems in the IT environment. The Dell systems management portfolio includes several powerful consoles, depending upon your needs, including the following:

- **Dell OpenManage Essentials** — OpenManage Essentials (OME) is a recently released systems management console that provides a comprehensive view of Dell systems, devices and components in an enterprise network. It is used to monitor Dell PowerEdge servers, EqualLogic™ and PowerVault™ storage and Dell Networking switches; to update and configure Dell servers; and to create asset reports. OME also communicates health status alerts for Dell servers, storage and network devices to the Dell KACE™ K1000 service desk. OME is available as a no-charge software download from Dell.com/Support.

OpenManage systems management tools and utilities

Dell OpenManage systems management tools and utilities consist of the following:

- **Dell Repository Manager** — The Dell Repository Manager (RM) is a standalone GUI-based productivity tool that helps simplify the process of managing downloads and baseline BIOS, firmware, and driver updates. RM can create deployment disks as well as create and manage customized repositories.
- **Dell OpenManage Server Update Utility** — The Dell Server Update Utility (SUU) is a DVD-based application for identifying and applying BIOS and firmware updates to your Dell PowerEdge servers.
- **Dell OpenManage Systems Build and Update Utility** — The Dell System Build and Update Utility (SBUU) provides one-to-one and one-to-many deployment and single-server update capabilities in the pre-operating system environment.
- **Dell Update Packages** — The Dell Update Packages (DUP) is a self-contained executable in a standard package format that updates a software element on a Dell server such as the BIOS, a driver, firmware and other software updates.
- **Dell OpenManage Deployment Toolkit** — The Dell OpenManage Deployment Toolkit (DTK) is a CLI-based tool that includes a set of utilities for configuring and deploying Dell PowerEdge systems, and can be used to build scripted, unattended OS installations to deploy large numbers of servers in a reliable fashion.



- **RACADM** — The RACADM command-line utility provides a scriptable interface that allows you to locally or remotely configure iDRAC7.
- **IPMITool** — IPMITool includes scriptable console application programs used to control and manage remote systems using the IPMI version 1.5 and later protocol.

Integration with third-party consoles

Dell OpenManage easily integrates with several leading third-party consoles, including:

- **Dell Server Management Pack Suite for Microsoft System Center Operations Manager** — This suite of server management packs enables several functions through System Center Operations Manager (SCOM), including in-band discovery and monitoring of racks and towers, out-of-band discovery and monitoring through iDRAC7 with Lifecycle Controller, as well as performance and advanced monitoring.
- **Dell Lifecycle Controller Integration for Microsoft System Center Configuration Manager** — This pack contains Dell Lifecycle Controller Integration (DLCI), which integrates OpenManage functions in the Microsoft System Center Configuration Manager (SCCM) to manage the Dell PowerEdge servers, including auto-discovery, operating system deployment and configuration of hardware elements, (RAID, NIC, BIOS, iDRAC), OS and hypervisor agnostic updates, firmware management and system viewer utilities.
- **Dell Server PRO Management Pack for Microsoft System Center Virtual Machine Manager** — This pack manages Dell physical servers and hosts of virtual machines (VMs) by using Microsoft System Center Operations Manager/System Center Essentials (SCOM/SCE) and System Center Virtual Machine Manager (SCVMM). It provides guidance for remedial actions based on alerts to best manage virtual machines and handle the impacts appropriately.
- **OpenManage Integration for VMware vCenter** — This plug-in allows IT administrators to monitor, provision and manage the physical PowerEdge server hardware and firmware from a dedicated Dell menu accessed through the VMware vCenter console using the same role-based access control model as vCenter, combining physical server management.
- **BMC Software** — Dell and BMC Software work together to simplify IT by ensuring tight integration between Dell server, storage and network management functionality and the BMC Software process and data center automation products.

OpenManage Connections with third-party consoles

Dell OpenManage provides connections with many third-party consoles, including:

- **Dell OpenManage Connection for Computer Associates Network and Systems Management** — This connection allows you to monitor PowerEdge servers and PowerVault storage arrays from within the Computer Associates Network and Systems Management (CA NSM) console.
- **Dell OpenManage Connection for HP Operations Manager** — This connection enables several functions through HP Operations Manager, including auto-grouping, SNMP trap reception, global health monitoring and a context-sensitive launch of OpenManage Server Administrator.
- **Dell OpenManage Connection for IBM Tivoli Netcool/OMNIBus** — This connection provides event monitoring capabilities to monitor Dell PowerEdge servers and Dell EqualLogic systems. It allows event monitoring, automatic event correlation and launching device consoles from the Netcool/OMNIBus console.

Dell server management operations

Dell OpenManage systems management is centered on automating the server management lifecycle — deploy, update, monitor and maintain. To manage an infrastructure properly and



efficiently, you must perform all of these functions easily and quickly. iDRAC7 with Lifecycle Controller technology provides you with these intelligent capabilities embedded within the server infrastructure. This allows you to invest more time and energy on business improvements and less on maintenance. Figure 7 illustrates the various operations that can be performed during the server’s lifecycle.

Figure 7. Systems management server lifecycle



Table 22 lists the products that are available for one-to-one and one-to-many operations, and when they are used in the server’s lifecycle.

Table 22. One-to-one and one-to-many operations

Operation	One-to-one	One-to-many
Deploy	<ul style="list-style-type: none"> iDRAC7 with Lifecycle Controller GUI DTK SBUU 	<ul style="list-style-type: none"> Symantec Deployment Server OpenManage Integration for VMware vCenter KACE K1000 Appliance Lifecycle Controller Remote Services BMC BladeLogic integration with Lifecycle Controller
		<ul style="list-style-type: none"> Dell Server Deployment Pack (DSDP) for Microsoft System Center Configuration Manager and Dell Lifecycle Controller Integration (DLCI) for Microsoft System Center Configuration Manager



Operation	One-to-one	One-to-many	
Update	<ul style="list-style-type: none"> iDRAC7 with Lifecycle Controller GUI Repository Manager DUP SUU SBUU OpenManage Integration for VMware vCenter 	<ul style="list-style-type: none"> Dell OpenManage Essentials Lifecycle Controller Remote Services 	<ul style="list-style-type: none"> Dell Update Catalogs for Microsoft System Center Configuration Manager Dell Lifecycle Controller Integration (DLCI) for Microsoft System Center Configuration Manager
Monitor	<ul style="list-style-type: none"> iDRAC7 with Lifecycle Controller with GUI OMSA 	<ul style="list-style-type: none"> Dell OpenManage Essentials BMC ProactiveNet Performance Management integration with Lifecycle Controller Dell OpenManage Power Center 	<ul style="list-style-type: none"> OpenManage Integration for VMware vCenter BMC ProactiveNet Performance Management Integration with Lifecycle Controller Dell Server Management Pack Suite for Microsoft System Center Operations Manager (SCOM)
Maintain	<ul style="list-style-type: none"> IPMI iDrac7 with Lifecycle Controller GUI 	<ul style="list-style-type: none"> Lifecycle Controller Remote Services 	<p>Remediate:</p> <ul style="list-style-type: none"> Dell Server PRO Management Pack for Microsoft System Center Virtual Machine Manager (SCVMM) <p>Replace parts:</p> <ul style="list-style-type: none"> Dell Lifecycle Controller Integration (DLCI) for Microsoft System Center Configuration Manager

For additional detailed information on Dell's systems management portfolio, see the *Dell OpenManage Systems Management Overview Guide* on Dell.com/Support/Manuals.



Appendix A. Additional specifications

Module dimensions and weight

Figure 8 details the dimensions of the M820 module.

Figure 8. Module dimensions

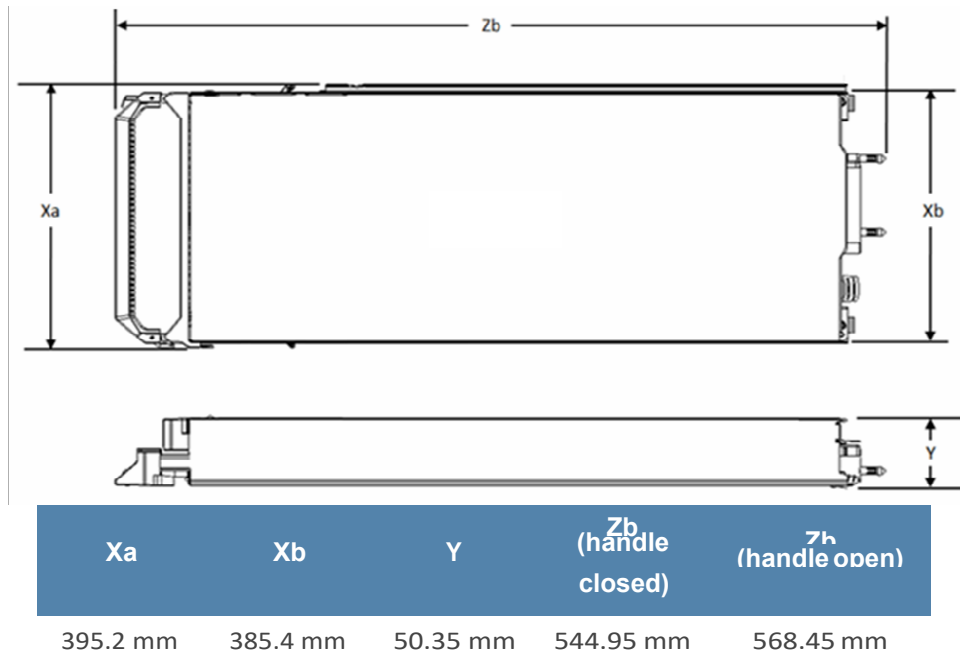

The weight of a maximum-configured M820 blade server is 14.5 kg (31.9 lb).

Video specifications

The Dell PowerEdge M820 iDRAC7 incorporates an integrated video subsystem. The graphics controller is the 2D Matrox® G200. The video frame buffer (16MB) is contained within the iDRAC RAM (256MB) device.

The M820 system supports the 2D graphics video modes in Table 23.

Table 23. Supported video modes

Resolution	Refresh rate (Hz)	Color depth (bit)
640 x 480	60, 72	8, 16, 32
800 x 600	60, 75, 85	8, 16, 32
1024 x 768	60, 75, 85	8, 16, 32
1152 x 864	60, 75, 85	8, 16, 32
1280 x 1024 (not available for UEFI)	60, 75	8, 16, 32



Environmental specifications

For additional information about environmental measurements for specific system configurations, see [Dell.com/environmental_datasheets](https://www.dell.com/environmental_datasheets). Table 24 details the environmental specifications for the M820.

Table 24. Environmental specifications

Fresh Air: temperature, humidity, altitude de-rating	
Continuous operation	10°C to 35°C (50°F to 95°F) at 10% to 80% relative humidity with 26°C (78.8°F) maximum dew point (maximum wet bulb temperature). De-rate maximum allowable dry bulb temperature at 1°C per 300 m above 950 m (1°F per 547 ft above 3117 ft).
Expanded operation	<p>When operating in the expanded temperature range, system performance may be impacted, and ambient temperature warnings may be reported on the LCD and in the System Event Log.</p> <p>≤ 10% of annual operating hours: 5°C to 10°C and 35°C to 40°C (with no direct sunlight on the equipment) at 5% to 85% relative humidity with 26°C dew point (maximum wet bulb temperature). Outside the standard operating temperature (10°C to 35°C), the system can operate down to 5°C or up to 40°C for a maximum of 10% of its annual operating hours. For temperatures between 35°C and 40°C (95°F to 104°F), de-rate maximum allowable dry bulb temperature by 1°C per 175 m above 950 m (1°F per 319 ft above 3117 ft).</p> <p>≤ 1% of annual operating hours: -5°C to 5°C and 40°C to 45°C (with no direct sunlight on the equipment) at 5% to 90% relative humidity with 26°C dew point (maximum wet bulb temperature). Outside the standard operating temperature (10°C to 35°C), the system can operate down to -5°C or up to 45°C for a maximum of 1% of its annual operating hours. For temperatures between 40°C and 45°C (104°F to 113°F), de-rate maximum allowable dry bulb temperature by 1°C per 125 m above 950 m (1°F per 228 ft above 3117 ft).</p> <p>Expanded operation restrictions:</p> <ul style="list-style-type: none"> • No cold startup below 5°C • Install only 87 mm wide heat sinks • Do not install more than 40 DIMMs
Temperature	
Operating	See Fresh Air for temperature information
Storage	-40°C to 65°C (-40°F to 149°F) with a maximum temperature gradation of 20°C per hour
Relative humidity	
Operating	See Fresh Air for relative humidity information
Storage	5% to 95% at a maximum wet bulb temperature of 33°C (91°F); atmosphere must be non-condensing at all times
Maximum vibration	
Operating	0.26 Grms at 5Hz to 350Hz for 15 minutes
Storage	1.54 Grms at 10Hz to 250Hz for 15 minutes



Maximum shock

Operating One shock pulse in the positive z axis (one pulse on each side of the system) of 31G for up to 2.6 ms

Storage Six consecutively executed shock pulses in the positive and negative x, y and z axes (one pulse on each side of the system) of 71G for up to 2 ms

Altitude

Operating -15.2 m to 3048 m (-50 ft to 10,000 ft)

Storage -15.2 m to 12,000 m (-50 ft to 39,370 ft)

Airborne contaminant level

Class G1 or lower as defined by ISA-S71.04-1985

USB peripherals

USB peripherals are supported through the front USB ports. They are USB 2.0 compliant.



Appendix B. Standards compliance

The M820 system conforms to the industry standards in Table 25.

Table 25. Industry standard documents

Standard	URL for information and specifications
ACPI Advance Configuration and Power Interface Specification, v2.0c	acpi.info
Ethernet IEEE 802.3-2005	standards.ieee.org/getieee802/802.3.html
HDG Hardware Design Guide Version 3.0 for Microsoft Windows Server	microsoft.com/whdc/system/platform/pcdesign/desguide/serv_erdg.mspx
IPMI Intelligent Platform Management Interface, v2.0	intel.com/design/servers/ipmi
DDR3 Memory DDR3 SDRAM Specification, Rev. 3A	jedec.org/download/search/JESD79-3C.pdf
LPC Low Pin Count Interface Specification, Rev. 1.1	developer.intel.com/design/chipsets/industry/lpc.htm
PCI Express PCI Express Base Specification Rev. 2.0 and 3.0	pcisig.com/specifications/pciexpress
PMBus Power System Management Protocol Specification, v1.2	pmbus.info/specs.html
SAS Serial Attached SCSI, v1.1	t10.org
SATA Serial ATA Rev. 2.6; SATA II, SATA 1.0a Extensions, Rev. 1.2	sata-io.org
SMBIOS System Management BIOS Reference Specification, v2.7	dmtf.org/standards/smbios/
TPM Trusted Platform Module Specification, v1.2	trustedcomputinggroup.org
UEFI Unified Extensible Firmware Interface Specification, v2.1	uefi.org/specifications
USB Universal Serial Bus Specification, Rev. 2.0	usb.org/developers/docs



Standard	URL for information and specifications
Windows Logo Windows Logo Program System and Device Requirements, v3.10	microsoft.com/whdc/winlogo/hwrequirements.aspx



Appendix C. Additional resources

Table 26 provides a list of documents and websites that provide for more information on the Dell PowerEdge M820.

Table 26. Additional resources

Resource	Description of contents	Location
Dell PowerEdge M820 Systems Owner's Manual	This manual, available in PDF format, provides the following information: <ul style="list-style-type: none"> • Chassis features • System Setup program • System messages • System codes and indicators • System BIOS • Remove and replace procedures • Troubleshooting • Diagnostics • Jumpers and connectors 	Dell.com/Support/Manuals
Dell PowerEdge M1000e Enclosure Owner's Manual	This manual provides information on the PowerEdge M1000e chassis enclosure and its supported blade server modules.	Dell.com/Support/Manuals
Dell PowerEdge M1000e, M915, M910, M820, M710HD, M710, M620, M610x, M610, M520 and M420 Getting Started Guide	This guide is printed and shipped with the system, and is also available in PDF format on the Dell support site. This guide provides information on the following: <ul style="list-style-type: none"> • Initial setup steps • Key system features • Technical specifications 	Dell.com/Support/Manuals
System Information Label	The system information label documents the system board layout and system jumper settings.	On the module
Quick Resource Locator (QRL)	This code on the chassis can be scanned by a phone application to access additional information and resources for the server, including videos, reference materials, service tag information and Dell contact information.	On the module
Information Update	This document is printed and shipped with the system, and is also available in PDF format on the Dell support site. This guide provides system update information.	Dell.com/Support/Manuals
PowerEdge M1000e Technical Guide	This guide provides detailed technical information on the M1000e chassis enclosure and its supported features.	Dell.com/PowerEdge



Resource	Description of contents	Location
Energy Smart Solution Advisor (ESSA)	The Dell online advisor console enables easier and more meaningful estimates to help you determine the most efficient configuration possible. Use ESSA to calculate the power consumption of your hardware, power infrastructure and storage.	Dell.com/ESSA
Power and cooling technologies	Provides details for improving energy efficiency in the data center.	Dell.com/PNC
Energy management	Provides information on Dell's Fresh Air cooling solutions.	Dell.com/FreshAir
Operating system matrix for Dell PowerEdge systems	Provides updated information on which operating systems are available on which PowerEdge systems.	Dell.com/OSsupport
Processor and chipset	Provides more information about the R620 processors and chipset.	Intel.com
Dell PowerEdge RAID controllers	Provides more information on Dell PowerEdge RAID controllers (PERC).	Dell.com/PERC
Power distribution unit (PDU)	Provides help selecting a power distribution unit.	DellPDU.com
Uninterruptible power supply (UPS)	Provides help selecting an uninterruptible power supply model.	DellUPS.com
Volatility information	Contact your Dell Sales Representative.	
Dell Enterprise Acoustics	White paper that explores the mechanisms of, people's reaction to, language of, and Dell's work to control noise from Enterprise products.	dell.com/downloads/global/products/pedge/en/acoustic-al-education-dell-enterprise-white-paper.pdf



Appendix D. System board block diagram

Figure 9. M820 system board block diagram

