

PowerEdge R920

Technical Guide



The PowerEdge R920—
a compute-intensive
rack server designed to
run mission-critical
applications for
midsized and large
enterprises.

This document is for informational purposes only and may contain typographical errors and technical inaccuracies. The content is provided as is, without express or implied warranties of any kind.

Dell, the DELL logo, PowerEdge, EqualLogic, PowerVault, OpenManage, KACE, and ReadyRails are trademarks of Dell, Inc. Intel and Xeon are registered trademarks of Intel Corporation in the U.S. and other countries. Microsoft, Windows, Windows Server, SQL Server, BitLocker, ActiveX, Internet Explorer, and Hyper-V are either registered trademarks or trademarks of Microsoft Corporation in the United States and/or other countries. SUSE is a registered trademark of Novell, Inc. in the United States and other countries. IBM, Tivoli, and Netcool are registered trademarks of IBM in the United States. Other trademarks and trade names may be used in this document to refer to either the entities claiming the marks and names or their products. Dell disclaims proprietary interest in the marks and names of others.

March 2014 | Version 1.0

Table of Contents

1	System overview	6
	Introduction	6
	New technologies.....	6
2	System features	8
	Comparison of PowerEdge systems.....	8
	Specifications	9
3	Chassis views and features.....	11
	Chassis views.....	11
	Chassis features.....	12
4	Processors	15
	Processor features	15
	Supported processors	15
	Chipset.....	16
5	Memory	17
	Supported memory	17
	Memory RAS features	18
	Mirroring and Dell Fault Resilient Memory	19
6	Storage.....	20
	Dell PowerEdge Express Flash NVMe PCIe SSDs.....	20
	Supported RAID controllers	20
7	Networking and PCIe	21
	PCIe expansion	22
	PCIe slots.....	22
8	Power, thermal and acoustics	24
	Power consumption and energy efficiency.....	24
	Power supply units	25
	Thermal design	25
	Acoustical design	26
	Fans	27
9	Rack rails and cable management	28
	Sliding rail system.....	29
	Cable Management Arm (CMA) and Strain Relief Bar (SRB)	30
10	Operating systems and virtualization	31
	Supported operating systems	31
	Supported virtualization.....	32
11	Dell OpenManage systems management.....	33
	Systems management solutions	33
	OpenManage systems management	34
	iDRAC7 with Lifecycle Controller	34
	Dell consoles	37
	OpenManage systems management tools and utilities.....	37
	Integration with third-party consoles.....	38
	OpenManage integration and connections with third-party consoles	38
	Dell server management operations	39
Appendix A.	Additional specifications	41
	Chassis dimensions and weight.....	41
	Video specifications	41

Environmental specifications	42
Appendix B. Standards compliance	43
Appendix C. Additional resources	45
Appendix D. Block diagram	47
Appendix E. Dell Global Support and Deployment Services	48
Server deployment services	48
Remote consulting services	49
ProSupport Enterprise Suite.....	49
ProSupport Plus for business-critical servers	49
ProSupport	50
ProSupport Flex for Data Center	50
Additional professional services	51
Dell Training Services.....	51
Dell IT Consulting Services.....	51
Dell Managed Services.....	51

Tables

Table 1. New technologies	6
Table 2. Comparing the PowerEdge R920 to the PowerEdge R910.....	8
Table 3. Technical specifications.....	9
Table 4. Chassis features	12
Table 5. Security features	14
Table 6. Supported processors	15
Table 7. Memory technologies supported	17
Table 8. Supported DIMMs	18
Table 9. Memory RAS features	18
Table 10. Supported RAID controller	20
Table 11. Network daughter card features	21
Table 12. Select Network Adapter selection for racks	21
Table 13. PowerEdge R920 RNDC options	22
Table 14. Power tools and technologies.....	24
Table 15. PowerEdge R920 ReadyRails II.....	29
Table 16. Supported rack types	29
Table 17. PowerEdge R920 supported operating systems.....	31
Table 18. Virtualization support	32
Table 19. iDRAC7 with Lifecycle Controller functions and benefits.....	34
Table 20. Feature comparison for iDRAC7 Express and Enterprise	35
Table 21. One-to-one and one-to-many operations	40
Table 22. Supported video modes.....	41
Table 23. Environmental specifications.....	42
Table 24. Industry standard documents.....	43
Table 25. Resource documents and websites	45

Figures

Figure 1. Front panel view	11
Figure 2. Back panel view.....	11
Figure 3. Internal chassis view	12
Figure 4. Quick Resource Locator.....	13
Figure 5. Dell Fault Resilient Memory.....	19
Figure 6. ReadyRails II mounting interface	28

Figure 7. R920 Sliding Rails with optional CMA.....	29
Figure 8. Dell systems management solutions	34
Figure 9. Systems management server lifecycle.....	39
Figure 10. R920 block diagram	47

1 System overview

Introduction

Designed to run mission-critical applications for midsized and large enterprises, the Dell™ PowerEdge™ R920 is a compute-intensive rack server with highly scalable memory and impressive I/O capabilities to match. With up to four Intel® Xeon® E7 v2 multi-core processors, the ability to support dual RAID controllers and up to 6TB of memory, the PowerEdge R920 can readily handle the most demanding workloads and is ideal for large databases, Enterprise Resource Planning, e-commerce, business decision applications and high-performance computing. The PowerEdge R920 is also an excellent choice for organizations looking to migrate from an outdated RISC architecture.

Scale to match the challenge

React at the speed of business with the R920's highly scalable memory, I/O options and storage components. With four Intel Xeon E7 v2 processors, 96 DIMMs, 10 integrated PCI Express® (PCIe) expansion slots and 24 internal storage drives, the R920 gives you processing power, flexibility and capacity for growth. Build out your SAN capacity as your business grows. Keep pace with the increasing data demands of large enterprise applications with H730P PERC, dual PERC capability and up to eight NVMe Express Flash PCIe SSDs.

Get results faster

Accelerate the time it takes enterprise applications to deliver services by eliminating the chokepoint — the speed of access to data. Use the R920's 24 internal storage drives, or take advantage of its 10 PCIe expansion slots to drive large scale SAN storage. With options like high-performance 12Gbps SAS drives, dual RAID controller capabilities and Express Flash NVMe devices, you can reduce storage access times and improve overall application efficiency.

Enterprise-wide systems management

PowerEdge embedded management technology, integrated Dell Remote Access Controller 7 (iDRAC7) with Lifecycle Controller, helps IT administrators manage Dell servers in physical, virtual, local and remote environments — agent-free or in-band with a systems management software agent installed. iDRAC7 Enterprise features include a multi-administrator virtual console, virtual media and remote file share that enable IT admins to operate servers “as if they were there,” ensuring secure access to servers from anywhere in the world. OpenManage™ Essentials, a comprehensive monitoring and management console, available as a no-charge software download, simplifies and automates basic hardware management tasks while Dell SupportAssist helps you maintain a healthy and productive environment.

New technologies

Table 1 summarizes new technologies featured on the Dell PowerEdge R920 rack server.

Table 1. New technologies

New technology	Detailed description
Intel Xeon processor E7-4800 v2, E7-8800 and E7-2800 v2 product families	This new family of Intel processors has embedded PCIe lanes for improved I/O performance. See the Processors section for details.

New technology	Detailed description
Intel C602J chipset	The R920 server uses the Intel Platform Controller Hub (PCH) chip.
1600MT/s DDR3 memory	Certain models of the Intel Xeon processor E7-4800 v2 product family support 1600MT/s memory. See the Memory section for details.
Flexible LAN	The Dell Select Network Adapter options allow you to customize your LAN port combinations from your choice of controller vendors. See the Networking and PCIe section for details.
LRDIMM	Load reduced DIMM (LRDIMM) is designed with a buffer chip (or chips) to replace the register to help minimize loading. LRDIMM is targeted to increase overall server system memory capacity and speed using a memory buffer chip or chips as opposed to a register. See the Memory section for more details.
Next-generation PERC options	The R920 supports the new PERC9 controller cards with improved functionality and faster performance. See the Storage section for details.
Dell PowerEdge Express Flash NVMe PCIe SSDs	A high-performance, solid-state storage device that enables high IOPS throughput, far surpassing that of conventional rotating hard drives. See the Networking and PCIe section for details.
iDRAC7 with Lifecycle Controller	The new embedded system management solution for Dell PowerEdge servers features hardware and firmware inventory and alerting, in-depth memory alerting, faster performance, a dedicated gigabit port and many more features. See the Dell OpenManage systems management section for details.
DC power supply	A new 1100W DC power supply option is available for the R920. See the Power, thermal and acoustics section for details.
Advanced power management	The R920 supports advanced power monitoring and power capping tools that can help manage power consumption in a data center. See the Power, thermal and acoustics section for details.
Fresh Air cooling	Dell has tested and validated an integrated data center solution that enables you to operate at higher temperatures or even chiller-less. See the Power, thermal and acoustics section for details.
Failsafe hypervisors	The internal dual SD module enables Dell's unique Failsafe Virtualization architecture, ensuring uptime by providing failover capability for embedded hypervisors, such as VMware vSphere ESXi™.

2 System features

The PowerEdge R920 is Dell's fastest four-socket 4U server with more drive bay options over previous generations, PCIe 3.0 slots, more memory, the ability to support dual RAID controllers, support for Express Flash PCIe SSDs, iDRAC7 Enterprise, and flexible configuration options to tailor a system to your exact requirements.

Comparison of PowerEdge systems

The PowerEdge R920 is a direct replacement for the R910. Table 2 compares some of the features of the R920 to the R910. For the latest information on supported features, visit Dell.com/PowerEdge.

Table 2. Comparing the PowerEdge R920 to the PowerEdge R910

Specification	PowerEdge R920	PowerEdge R910
Chassis	Rack 4S/4U	Rack 4S/4U
Processors	Intel Xeon processor E7-4800 v2 and E7-8800 v2 product families (up to 4); Intel Xeon processor E7-2800 v2 product family (up to 2)	Intel Xeon processor E7 4800 and E7-8800 product families
Memory	96 DIMM slots, up to 6TB	64 DIMM slots, up to 2TB
Drive bays	<ul style="list-style-type: none">Up to 24 2.5" hot-plug 12Gb/6Gb SAS HDD or SAS/SATA SSDUp to 8 front-accessible Express Flash NVMe PCIe SSD (PCIe 3.0)	<ul style="list-style-type: none">Up to 16 2.5" SATA SSD, SAS, nearline SAS, or SATA drives
RAID	PERC H730P, H810 Dual PERC option	PERC H200, H700, H800
PCI slots	<ul style="list-style-type: none">8 PCIe 3.0 slots (two x8 + six x16)Optional PCIe riser to add two additional slots for 10 total	<ul style="list-style-type: none">7 PCIe 2.0 slotsOptional PCIe riser to add 3 additional slots for 10 total
Onboard NICs	Flexible LOM options	2 options – (1) 4 x1GbE or (2) 2 x1GbE + 2 x 10Gb
Power supplies and power efficiency	Hot-plug redundant PSUs: 750W AC Platinum 750W AC Titanium 1100W (AC & DC)	Hot-plug redundant PSUs: 750W AC Gold 1100W AC Gold
Management	Dell OpenManage portfolio	Dell OpenManage portfolio
Remote Management	iDRAC7 Express with Lifecycle Controller (standard) iDRAC7 Enterprise with Lifecycle Controller (optional)	iDRAC6 with Lifecycle Controller
Availability	Hot-plug drives, Hot-plug power supply units Hot-plug fans	Hot-plug drives, Hot-plug power supply units Hot-plug fans

Specifications

Table 3 summarizes the product features for the PowerEdge R920. For the latest information on supported features for the PowerEdge R920, visit [Dell.com/PowerEdge](https://www.dell.com/poweredge).

Table 3. Technical specifications

Feature	PowerEdge R920 technical specification
Form factor	4U rack
Processors	Intel Xeon processor E7-4800 v2 and E7-8800 v2 product families (up to 4) Intel Xeon processor E7-2800 v2 product family (up to 2)
Internal interconnect	Intel Quick Path Interconnect v. 1.1
Chipset	Intel C602J
Memory	Up to 6TB (96 DIMM slots): 4GB/8GB/16GB/32GB/64GB DDR3L, RDIMM, LR-DIMM up to 1600MT/s
I/O slots	Up to 10 PCIe slots; 8 PCIe 3.0, + 1 RAID slot, + 1 NDC slot + 2 optional PCIe slots
RAID controller	Internal controllers: PERC H730P External HBAs (RAID): PERC H810 6Gbps SAS HBA
Drive bays	<ul style="list-style-type: none"> • Up to 24 2.5" hot-plug 12Gb/6Gb SAS HDD or SAS/SATA SSD • Up to 8 front-accessible Express Flash NVMe PCIe SSD (PCIe 3.0)
Supported drives	Hot-plug hard drive options: 2.5" SATA/SAS SSD, SAS HDD (15K, 10K), nearline SAS HDD (7.2K) 2.5" PCIe SSDs: Dell PowerEdge NVMe Express Flash PCIe SSD
Embedded NIC	Broadcom [®] 5720 quad-port 1Gb NDC Broadcom 57800 2x10Gb DA/SFP+ + 2x1Gb BT NDC Broadcom 57800 2x10Gb BT + 2x1Gb BT network daughter card Intel I350 quad-port 1GbE network daughter card Intel X520 dual-port 10Gb DA/SFP+, + I350 DP 1GbE NDC Intel Ethernet Converged Network Adapter X540, 10Gb BT DP + I350 1Gb BT dual-port NDC
Power supplies	Hot-plug redundant PSUs: 750W AC, 1100W AC and DC
Availability	Hot-plug hard drives, hot-plug redundant power, hot-plug redundant fans, ECC memory, internal dual SD module
Video	Matrox [®] G200 with 8MB memory
Remote management	iDRAC7 with Lifecycle Controller <ul style="list-style-type: none"> • iDRAC7 Express (default) • iDRAC7 Enterprise (upgrade option) • 8GB or 16GB vFlash media (upgrade options)

Feature**PowerEdge R920 technical specification****Systems Management**

- IPMI 2.0 compliant
- Dell OpenManage Essentials
- Dell OpenManage Mobile
- Dell OpenManage Power Center
- Dell OpenManage Integrations:
 - Dell OpenManage Integration Suite for Microsoft System Center
 - Dell OpenManage Integration for VMware vCenter
- Dell OpenManage Connections:
 - HP Operations Manager, IBM Tivoli Netcool, and CA Network and Systems Management
 - Dell OpenManage Plug-in for Oracle Database Manager.

¹GB means 1 billion bytes and TB equals 1 trillion bytes; actual capacity varies with preloaded material and operating environment and will be less.

3 Chassis views and features

The PowerEdge R920 features a new chassis design that supports advanced memory capacity through additional DIMMs, PCI slots and increased hard drive spindle count.

Chassis views

Figure 1. Front panel view

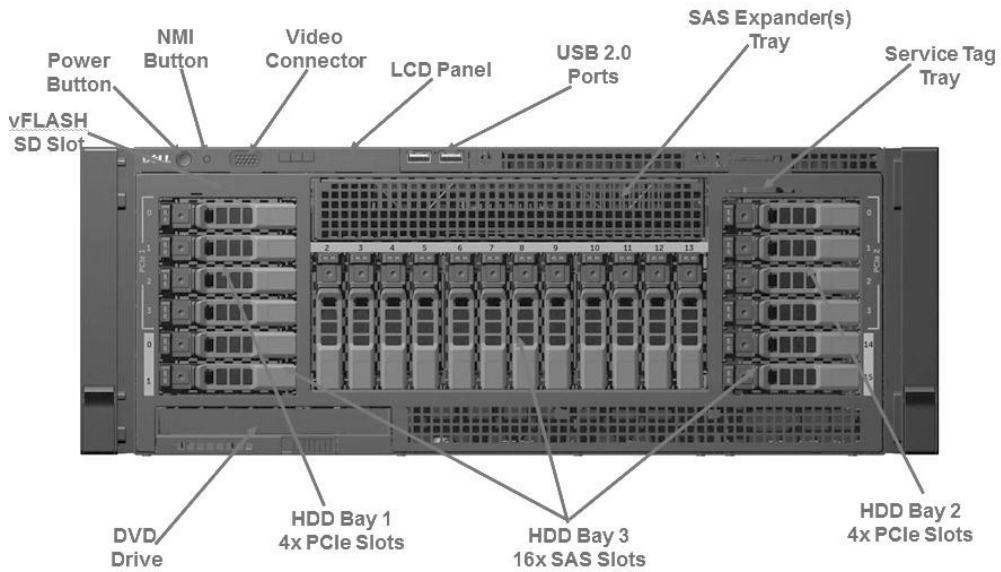

Figure 2. Back panel view

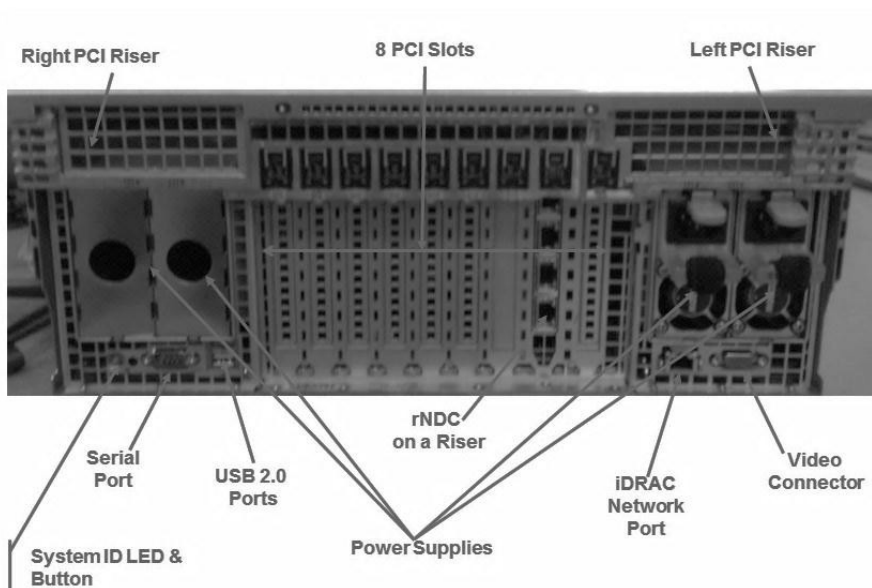
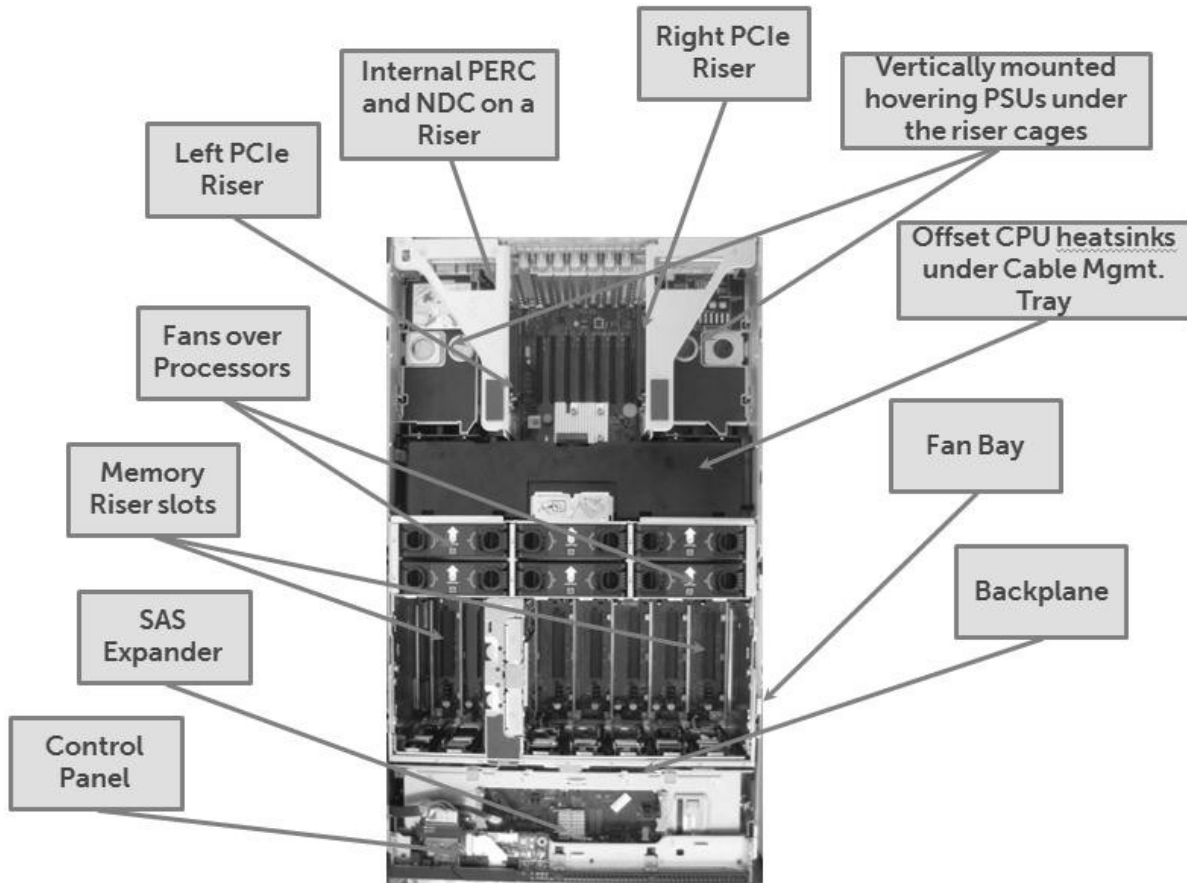

Figure 3. Internal chassis view



Chassis features

Table 4 lists the features on the R920 chassis. For additional information, see the *Dell PowerEdge R920 Owner's Manual* on Dell.com/Support/Manuals.

Table 4. Chassis features

Feature	Description
Power-on indicator, power button	The power-on indicator lights when system power is on. The power button controls the DC power supply output to the system.
NMI button	Used to troubleshoot software and device driver errors with certain operating systems; use only if directed to do so by qualified support personnel or by the operating system's documentation.
System identification button	Buttons on the back and front of a system to help identify the unit in a data center environment.

Video connector	Connects a monitor to the server.
LCD menu buttons	Allows you to navigate the control panel LCD menu.
Information tag	A slide-out label panel for system information including the Express Service tag, Embedded NIC1 MAC address, and iDRAC7 Enterprise card MAC address.
LCD panel	Displays system ID, status information and system error messages.
Optical drive	One optional SATA DVD-ROM drive or DVD+/-RW drive
Hard drives	<ul style="list-style-type: none"> Up to 24 2.5" hot-plug 12Gb/6Gb SAS HDD or SAS/SATA SSD Up to 8 Express Flash NVMe PCIe SSD (PCIe 3.0)
USB connectors	Two USB 2.0-compliant ports in the front, and two in the rear, connect USB devices to the server.
vFlash media card slot	Allows insertion of a vFlash media card.
Ethernet connectors	Connects integrated 10/100/1000 NICs to the server
Power supply units	Supplies power to the server
PCIe slots	Up to 10 PCIe slots; 8 PCIe 3.0, + 1 RAID slot, + 1 NDC slot + 2 optional PCIe slots
iDRAC7 Enterprise port	Allows you to navigate the control panel LCD menu

Quick Resource Locator (QRL)

The PowerEdge R920 features a Quick Resource Locator — a model-specific Quick Response (QR) code located inside the R920 chassis cover (see Figure 4). Use your smartphone to access the Dell QRL app to learn more about the server.

Figure 4. Quick Resource Locator



The QR code provides quick access to:

- Step-by-step videos, including overviews of system internals and externals, as well as detailed, concise task-oriented videos and installation wizards
- Reference materials, including searchable owner's manual content, LCD diagnostics, and an electrical overview
- Service tag lookup, so you can quickly gain access to your specific hardware configuration info and warranty information

Contact with Dell via a direct link to get in touch with technical support and sales teams, and provide feedback direct to Dell

These codes provide an easy way to retrieve critical support information when you need it, making you more efficient and effective at managing your data center hardware.

Security features

The latest generation of PowerEdge servers has the features listed in Table 5 to help ensure the security of your data center.

Table 5. Security features

Security feature	Description
Cover latch	A tooled latch is integrated in the side cover to secure it to the rack chassis.
Bezel	A metal bezel is mounted to the chassis front to provide the Dell ID. A lock on the bezel is used to protect un-authorized access to hard drives. System status is viewable on the LCD screen when the bezel is installed.
TPM	The Trusted Platform Module (TPM) is used to generate/store keys, protect/authenticate passwords and create/store digital certificates. It also supports the Intel Xeon TXT functionality. TPM can also be used to enable the BitLocker™ hard drive encryption feature in Windows Server 2008. TPM 1.2 is supported. The China TCM solution is not supported on R920. No TPM version is available for China or Russia.
Power-off security	BIOS has the ability to disable the power button function.
Intrusion alert	A switch mounted on riser three detects chassis intrusion. When iDRAC is enabled, the switch circuit closes to indicate intrusion when the cover is opened.
Secure mode	BIOS has the ability to enter a secure boot mode through system setup. This mode includes the option to lock out the power and NMI switches on the control panel or set up a system password.

4 Processors

The PowerEdge R920 features the Intel Xeon processor E7-4800 v2, E7- 8800 v2 and E7-2800 v2 product families with advanced reliability, availability and serviceability (RAS) features to keep your business operations running and minimize unnecessary downtime. With its high memory capacity, the R920 is ideal for data-demanding, transaction-intensive workloads, such as ERP, CRM, HPC, and in-memory database systems.

Processor features

- ❓ Up to 15 cores in each processor
- ❓ Eight DDR3 channels per socket
- ❓ Up to 1600MT/s DDR3 speeds
- ❓ Advanced RAS features of Intel Run Sure Technology, designed to reduce frequency and cost of downtime while protecting data integrity. Intel Run Sure Technology provides 40 reliability features, including:
 - > Enhanced Machine Check Architecture Gen 1 (eMCA 1) provides advanced error log data to system firmware and the OS to improve system diagnostic and predictive failure analysis
 - > Machine Check Architecture (MCA) recovery — Execution Path offers the capability for a system to continue to operate even when the processor is unable to correct data errors within the memory sub-system and allows software layers to participate in system recovery
 - > MCA for I/O provides improved diagnostics and reduce service costs, this feature provides information on uncorrected I/O errors to the OS so that it can take appropriate actions.
 - > PCIe Live Error Recovery (LER) can increase system uptime and extend recovery and containment from PCIe errors.

Supported processors

The PowerEdge R920 supports up to four E7-4800 v2 and E7-8800 v2 processors, or two E7-2800 v2 processors. Intel Xeon processors supported by the PowerEdge R920 are listed in Table 6. For the latest information on supported processors, visit Dell.com/PowerEdge.

Table 6. Supported processors

Model	Speed	TDP	Cache	Cores/Threads	QPI	Turbo	MaxMemory
XeonE7-8893v2	3.4GHz	155W	37.5M	6/12	8.0GT/s	Yes	1600
XeonE7-8891v2	3.2GHz	155W	37.5M	10/20	8.0GT/s	Yes	1600
XeonE7-8880Lv2	2.2GHz	105W	37.5M	15/30	8.0GT/s	Yes	1600
XeonE7-8857v2	3.0GHz	130W	30M	12/12	8.0GT/s	Yes	1600
XeonE7-4890v2	2.8GHz	155W	37.5M	15/30	8.0GT/s	Yes	1600
XeonE7-2890v2	2.8GHz	155W	37.5M	15/30	8.0GT/s	Yes	1600
XeonE7-4880v2	2.5GHz	130W	37.5M	15/30	8.0GT/s	Yes	1600
XeonE7-2880v2	2.5GHz	130W	37.5M	15/30	8.0GT/s	Yes	1600
XeonE7-4870v2	2.3GHz	130W	30M	15/30	8.0GT/s	Yes	1600

XeonE7-2870v2	2.3GHz	130W	30M	15/30	8.0GT/s	Yes	1600
XeonE7-4860v2	2.6GHz	130W	30M	12/24	8.0GT/s	Yes	1600
XeonE7-4850v2	2.3GHz	105W	24M	12/24	7.2GT/s	Yes	1600
XeonE7-2850v2	2.3GHz	105W	24M	12/24	7.2GT/s	Yes	1600
XeonE7-4830v2	2.2GHz	105W	20M	10/20	7.2GT/s	Yes	1600
XeonE7-4820v2	2.0GHz	105W	16M	8/16	7.2GT/s	Yes	1600
XeonE7-4809v2	1.9GHz	105W	12M	6/12	6.4GT/s	NA	1333

For information on processor installation and configuration, see the *Dell PowerEdge R920 Owner's Manual* on Dell.com/Support/Manuals.

Chipset

The PowerEdge R920 uses the Intel C602J chipset. For more information, visit Intel.com.

5 Memory

More memory options are available than ever before with the Dell PowerEdge R920 — greater capacities, higher frequencies and more flexibility. The R920 supports up to 6TB of LRDIMM memory (with 96 x 64GB LRDIMMs); up to 3TB of LRDIMM memory (with 96 x 32GB LRDIMMs) and up to 1.5TB of RDIMM memory (with 48 x 16GB RDIMMs.)

In addition to supporting registered DIMMs (RDIMM), the R920 supports load reduced DIMMs (LRDIMM), which use a buffer to reduce memory loading and provide greater density, allowing for the maximum platform memory capacity. High memory density provides a richer, no compromise virtualization environment. While the buffer in the LRDIMM reduces memory bus loading and allows 50% higher capacity in a system, the buffer does introduce additional latency, which will have a small impact on system performance.

Increase your uptime and reduce data loss with reliability, availability and serviceability (RAS) features like memory mirroring, sparing and many others. RAS aids in the rapid and accurate diagnosis of faults that require service, increasing your memory reliability.

Supported memory

The R920 supports the memory technologies shown in Table 7.

Table 7. Memory technologies supported

Feature	RDIMM	LRDIMM
Register	Yes	Yes
Buffer	No	Yes
Frequencies*	1600MT/s	1600MT/s
Ranks supported	1 or 2	4 or 8
Capacity per DIMM	4, 8 or 16GB	32 or 64GB
Maximum DIMMs per channel	3	3
DRAM technology	x4	X8
Temperature sensor	Yes	Yes
Error Correction Code (ECC)	Yes	Yes
Enhanced Single Device Data Correction (SDDC +1)	Yes, x8 (lockstep)	Yes, x8 (lockstep)
Enhanced DRAM Double Device Data Correction (DDDC +1)	Yes, x4 (lockstep)	Yes, x4 (lockstep)
Address parity	Yes	Yes

The R920 supports the DIMMs listed in Table 8. For the latest information on supported memory, visit Dell.com/PowerEdge.

Table 8. Supported DIMMs

Capacity (GB)	Speed (MT/s)	Type	Ranks per DIMM	Data width	SDDC support	Voltage
4	1600 ¹	RDIMM	1	x8	Advanced ECC	1.35
8	1600	RDIMM	1	x4	lockstep mode	1.35
16	1600	RDIMM	2	x4	lockstep mode	1.35
32	1600	LRDIMM	4	x4	lockstep mode	1.35
64	1600	LRDIMM	8	x4	lockstep mode	1.35

¹Actual operational frequency could be lower than 1600MT/s depending on DIMM type, rank, number of DIMMs per channel and memory mode.

Memory RAS features

RAS features help keep the system online and operational without significant impact to performance, and can decrease data loss and crashing due to errors. RAS aids in rapid, accurate diagnosis of faults that require service. Table 9 describes the RAS features supported on the R920.

Table 9. Memory RAS features

Feature	Description
Dense configuration optimized profile	Increased memory reliability can be a result from this selectable platform profile that adjusts parameters to reduce faults regarding refresh rates, speed, temperature and voltage
Memory demand and patrol scrubbing	Demand scrubbing is the ability to write corrected data back to the memory once a correctable error is detected on a read transaction. Patrol scrubbing proactively searches the system memory, repairing correctable errors.
Recovery from single DRAM device failure	Recovery from Single DRAM Device Failure (SDDC) provides error checking and correction that protects against any single memory chip failure as well as multi-bit errors from any portion of a single memory chip.
Failed DIMM isolation	This feature provides the ability to identify a specific failing DIMM channel pair, thereby enabling the user to replace only the failed DIMM pair.
Memory mirroring: intra-socket	Memory mirroring is a method of keeping a duplicate (secondary or mirrored) copy of the contents of memory as a redundant backup for use if the primary memory fails. The mirrored copy of the memory is stored in memory of the same processor socket.
Memory address parity protection	This feature provides the ability to detect transient errors on the address lines of the DDR channel.
Memory sparing (rank)	Memory sparing allocates one rank per channel as a spare. If excessive correctable errors occur in a rank or channel, it is moved to the spare area while the operating system is running to prevent the error from causing an uncorrectable failure.
Memory thermal throttling	This feature helps to optimize power/performance and can also be used to prevent DIMMs from overheating.

For information on memory mirroring and sparing configurations, see the *Dell PowerEdge R920 Owner's Manual* on Dell.com/Support/Manuals.

Mirroring and Dell Fault Resilient Memory

The PowerEdge R920 supports memory mirroring. Partial mirroring is enabled through Dell Fault Resilient Memory (FRM). Available on Dell PowerEdge 12th generation servers, FRM establishes an area of memory that is fault resilient and can be used by an operating system supporting the FRM feature to load critical applications and maximize system availability.

Benefits:

- ❓ Creates a highly resilient memory zone for the hypervisor, protecting it from all but the most severe memory errors.
- ❓ With VMware
 - , vSphere v5.5, FRM provide the hypervisor with strong protection from memory faults that would otherwise bring down the entire system. When used in conjunction with other Dell PowerEdge reliability and redundancy features for virtualization — such as the internal dual SD modules — it creates a highly reliable VMware virtualization server environment with high availability and uptime.

Figure 5. Dell Fault Resilient Memory



6 Storage

The PowerEdge R920 supports extensive internal and external storage options. Support for internal storage includes a number of variations with a 2.5" drive chassis. For external storage, there are a number of storage options that range from JBOD connectivity to SAN support with Dell Compellent. Connectivity options include: host bus adaptors (HBA) options for SAS, iSCSI and Fibre Channel.

New server storage features such as Express Flash NVMe PCIe SSDs and software caching solutions provide accelerated application/workload performance over previous technologies. Express Flash drives use PCIe bus lanes to connect directly to the processor and chipset and are easily accessible through the hot-plug drive bay.

Dell PowerEdge Express Flash NVMe PCIe SSDs

The PowerEdge R920 supports up to eight PowerEdge Express Flash NVMe PCIe SSDs, high-performance storage devices designed for solutions requiring ultra-low latency, high input/output operations per second (IOPs) and enterprise-class storage reliability and serviceability. With a choice of 400GB, 800GB and 1.6TB capacities, PowerEdge Express Flash NVMe PCIe SSDs interact with and optimize high-performance NAND, achieving ultra-high IOPs and sequential read/write speeds. Express Flash NVMe PCIe SSDs deliver exceptional performance in demanding enterprise environments, such as blade and enterprise servers, online transactional processing (OLTP) databases, video-on-demand servers, web accelerators and virtualization workloads.

For information on Dell PowerEdge Express Flash NVMe PCIe SSDs, visit Dell.com/PowerEdge/ExpressFlash.

Supported RAID controllers

The newest line of PowerEdge RAID Controller (PERC) cards offers high I/O performance for database applications and streaming digital media environments. Internal RAID controllers have a dedicated connection to the motherboard. The R920 supports the new PERC 8 family of controllers with improved functionality and faster performance.

The R920 supports the PERC cards listed in Table 10. For more information about the latest PERC offerings, see Dell.com/PERC.

Table 10. Supported RAIDcontroller

Controller	Description	Features	RAID modes supported	Form factor	Usage model
PERC H810 External	Eight-port, external and 6Gb/s PCIe RAID controller	Includes 1GB NV DDR3 cache, premium performance and feature set, security SED/EKMS, and SSD as cache	0, 1, 5, 6, 10, 50, 60	Adapter	Premium performance
PERC H730P Internal	12Gb/s SAS/6Gb/s SATA PCIe 3.0 2x4 internal adapter	PCIe 3.0 support and 12Gb/s SAS (SAS 3.0) host interface, 2GB NV Flash backed cache; capable of RAID as well as Non-RAID (JBOD Mode) operations	0, 1, 5, 6, 10, 50, 60	Adapter	Premium performance

7 Networking and PCIe

The PowerEdge R920 offers rack network daughter card (RNDC) options which provide a custom solution that contains a complete network interface controller (NIC) subsystem. The R920 supports one RNDC card instead of the traditional LAN on motherboard (LOM) design. RNDC offer the features and benefits of a traditional LOM subsystem (including NC-SI management interface) but with expanded features and added flexibility as RNDCs provide an easy upgrade path from 1GB to 10GB LAN speeds.

Table 11. Network daughter card features

Features	1GE	10GE
Link speed	10/100/1000Mbps	100Mbps/1GB/10GB
Link types	1000BASE-T	10GBASE-T, SFP+ DCA/SR
TCP Chimney (TOE)	No	Yes
iSCSI offload	No	Yes
FCoE offload	No	Yes
NetQueue/VMQ IOV	No	Yes
SRIOV	No	Yes
NIC partitioning (NPAR)	No	Yes
VNTag/VEB	No	Yes
Energy Efficient Ethernet	No	No
Stateless Offloads (RSS, CSO, LSO, LRO)	Yes	Yes
NC-SI pass-through and CEM	Yes	Yes

Table 12. Select Network Adapter selection for racks

	10Gb Ethernet	10Gb Converged		1Gb Ethernet	1Gb Converged
Running Protocols	LAN	LAN+ ISCSI	LAN+ FCoE	LAN+ISCSI+ FCoE	LAN+ISCSI

	10Gb Ethernet	10Gb Converged			1Gb Ethernet	1Gb Converged
Racks	Broadcom 57800 2x1Gb+2x10Gb SFP+	Broadcom 57800 2x1Gb+2x10Gb SFP+	-	-	Broadcom 5720 4x1Gb BT	Broadcom 5720 4x1Gb BT
	Intel i540 2x1Gb+32x10Gb BT	Intel X540 2x1Gb+2x10Gb BT	-	-	Intel i350 4x1Gb BT	Intel i350 4x1Gb BT

PCIe expansion

With 32 PCIe lanes available from each E7 v2 processor in the system, the R920 provides greatly expanded PCIe slot capability over previous-generation PowerEdge servers. Dell designed the R920 to be PCIe-3.0 compliant to take full advantage of the processor capabilities.

PCIe slots

PCIe connectivity is integrated with the processor in that the number of processors in a system impacts the number of PCIe slots and the bandwidth of each PCIe slot.

- Slot 1: half-length, full-height, PCIe 3.0 x8 (x24 connector), baseboard
- Slot 3: half-length, full-height, PCIe 3.0 x8 (x16 connector), baseboard
- Slot 4: half-length, full-height, PCIe 3.0 x16 (x16 connector), baseboard
- Slot 5: half-length, full-height, PCIe 3.0 x16 (x16 connector), baseboard
- Slot 6: half-length, full-height, PCIe 3.0 x16 (x16 connector), baseboard
- Slot 7: half-length, full-height, PCIe 3.0 x16 (x16 connector), baseboard
- Slot 8: half-length, full-height, PCIe 3.0 x16 (x16 connector), baseboard
- Slot 9: half-length, full-height, PCIe 3.0 x16 (x24 connector), baseboard
- Slot 1/1: full-length, full-height, PCIe 3.0 x4 (x8 connector), left riser
- Slot 2/2: half-length, full-height, PCIe 3.0 x4 (x8 connector), left riser
- Slot 1/9: full-length, full-height, PCIe 3.0 x8 (x16 connector), right riser
- Slot 2/10: half-length, full-height, PCIe 3.0 x8 (x16 connector), right riser

Table 12 lists the available network daughter card options for the R920.

Table 13. PowerEdge R920 RNDC options

Network daughter card	Adapter
1Gb/10Gb	Broadcom 5720 Quad-Port Rack 1Gb
	Broadcom 57800 2x10Gb DA/SFP++ + 2x1Gb Base-T
	Broadcom 57800 2x10Gb BT + 2x1Gb Base-T

Network daughter card	Adapter
	Intel Ethernet I350 Quad-Port 1Gb
	Intel X520 DP 10Gb DA/SFP+, + I350 DP 1Gb Ethernet, Network Daughter Card
	Intel Ethernet X540 10Gb BT DP + I350 1Gb BT DP Network Daughter Card

8 Power, thermal and acoustics

Lower overall system-level power draw is a result of breakthrough system design. The Dell PowerEdge R920 server maximizes performance per watt through a combination of power and cooling, energy-efficient technologies and tools. Additionally, the PowerEdge R920 has an extensive collection of sensors that automatically track thermal activity, which helps regulate temperature thereby reducing server noise and power consumption.

Power consumption and energy efficiency

With the rise in the cost of energy coupled with increasing data center density, Dell provides tools and technologies to help you realize greater performance with less energy cost and waste. More efficient data center usage can reduce costs by slowing the need for additional center space. Table 14 lists the tools and technologies Dell offers to help you achieve your data center goals by lowering power consumption and increasing energy efficiency.

Table 14. Power tools and technologies

Feature	Description
Power supply units (PSU) portfolio	Dell's PSU portfolio includes intelligent features such as dynamically optimizing efficiency while maintaining availability and redundancy. Find additional information in the Power, thermal and acoustics section.
Tools for right-sizing	Dell Energy Smart Solution Advisor (ESSA) is a tool that helps you determine the most efficient configuration possible. With ESSA, you can calculate the power consumption of your hardware, power infrastructure and storage. ESSA can help you determine exactly how much power your server will use at a given workload, and the PSU Advisor can help you choose the best, most efficient PSU for your workload. Learn more at Dell.com/ESSA .
Industry compliance	Dell's servers are compliant with all relevant industry certifications and guidelines, including 80 PLUS, Climate Savers and ENERGY STAR.
Power monitoring accuracy	PSU power monitoring improvements include: <ul style="list-style-type: none"> • Dell's power monitoring accuracy is currently 1%, whereas the industry standard is 5% • More accurate reporting of power • Better performance under a power cap
Power capping	Use Dell's systems management to set the power cap limit for your systems to limit the output of a PSU and reduce system power consumption. Dell is the first hardware vendor to leverage Intel Node Manager for circuit-breaker fast capping.
Systems management	iDRAC7 Enterprise provides server-level management that monitors, reports and controls power consumption at the processor, memory and system level. Dell OpenManage Power Center delivers group power management at the rack, row and data center level for servers, power distribution units and uninterruptible power supplies.

Feature	Description
Active power management	<p>Intel Node Manager is an embedded technology that provides individual server-level power reporting and power limiting functionality. Dell offers a complete power management solution comprised of Intel Node Manager accessed through Dell iDRAC7 Enterprise and OpenManage Power Center that allows policy-based management of power and thermals at the individual server, rack and data center level.</p> <p>Hot spare reduces power consumption of redundant power supplies.</p> <p>Thermal control of fan speed optimizes the thermal settings for your environment to reduce fan consumption and lower system power consumption.</p> <p>Idle power enables Dell servers to run as efficiently when idle as when at full workload.</p>
Fresh Air cooling	<p>With the thermal design and reliability of Dell products, certain configurations have the capability to operate at excursion-based temperatures beyond the industry standard of 35°C (95°F) up to 45°C (113°F) for excursionary periods of time and up to a 26°C dew point at 90% relative humidity; without impacting your availability model. Find additional information at Dell.com/FreshAir.</p>
Rack infrastructure	<p>Dell offers some of the industry's highest-efficiency power infrastructure solutions, including:</p> <ul style="list-style-type: none"> • Power distribution units • Uninterruptible power supplies • Energy Smart containment rack enclosures <p>Find additional information at content.dell.com/us/en/enterprise/power-and-cooling-technologies-components-rack-infrastructure.aspx.</p>

Power supply units

Energy Smart power supplies have intelligent features, such as the ability to dynamically optimize efficiency while maintaining availability and redundancy. Also featured are enhanced power-consumption reduction technologies, such as high-efficiency power conversion and advanced thermal-management techniques, and embedded power-management features, including high-accuracy power monitoring.

There are four power supply units available for the PowerEdge R920: which have auto sensing and auto switching capability:

- 🔗 750W AC Platinum
- 🔗 750W AC Titanium
- 🔗 1100W AC Platinum
- 1100W DC

Thermal design

The thermal design of the PowerEdge R920 reflects the following:

- 🔗 **Multiple sensors are monitored for thermal feedback control:** The PowerEdge R920 dynamically controls system cooling fan speed based on responses from all component temperature sensors, including processors, hard disk drives, DIMMs, storage cards and the inlet ambient temperature. Thermal management adjusts cooling according to what the

system really needs, drawing lower fan power to help the system generate lower acoustical noise levels than servers without such controls.

- **User-configurable settings:** An R920 thermal control design target is to minimize the contribution of fan power to overall system power. The default thermal setting is “DAPC” mode, performance per watt. However, thermal settings are available for customers who have other priorities. Available in the “iDRAC Settings” in the “System Setup Main Screen,” are “High Fan Speed Offset,” “Low Fan Speed Offset,” and “Maximum Air Exhaust Temperature.” For more information, see *the PowerEdge R920 System Owner’s Manual* on Dell.com/Support/Manuals.
- ❓ **Cooling redundancy:** The R920 allows continuous operation with a fan failure in the system.
- ❓ **Environmental specifications:** Optimized thermal management makes the R920 reliable under a wide range of operating environments as shown in the environmental specifications outlined in Table 23. Many configurations are also compliant under expanded operating temperature environments, but a few are not.

Acoustical design

The acoustical design of the PowerEdge R920 reflects the following:

- ❓ **Use:** The PowerEdge R920 is appropriate for use in a data center environment and is not intended for use in an open office space.
- **Adherence to Dell’s high sound quality standards:** Sound quality is different from sound power level and sound pressure level in that it describes how humans respond to annoyances in sound, like whistles, hums, etc. One of the sound quality metrics in the Dell specification is prominence ratio of a tone, and this is listed in the table below.
- **Noise ramp and descent during boot-up from power off:** Fan speeds hence noise levels ramp during the boot process (from “power off” to “power on”) in order to add a layer of protection for component cooling in the case that the system were not to boot properly. In order to keep the boot-up process from generating high noise levels, the system fan speeds reached during boot-up is limited to about half of full speed.
- ❓ **Noise level dependencies:** If acoustics is important to you, you may want to make the following configuration choices and settings for the PowerEdge R920 because they result in quieter operation.
 - > iDRAC BIOS settings: Performance Per Watt (DAPC or OS) will be quieter than Max Performance setting
 - > Adjust C1E mode to “ENABLED” if Max Performance setting is selected in the BIOS and the system is configured with any of the following processors: 130W, 12 core; 155W, 15 core; 155W, 10 core; or 155W, 6 core.
 - > Configure the system with 105W processors of any core count, or 130W processors of any core count, except 12 core. The system will maintain low fan speeds under most loading conditions when operating in typical data center ambient temperatures (~25C, 77°F)
- ❓ Some components cause significant but not necessarily intuitive increases in loudness when they are installed in R920, including the following: Fusion I/O, GPU, PCIe SSD, 10Gb NIC, CPU count, PCI card count, 10Gb NDC, HDD count and Dell PERC RAID card.

Fans

Six hot swappable fans are mounted in a fan gantry located in the chassis between the hard drive bay and the processors. Each fan has a blind mate 2x2 connector that plugs directly into the fan tray. An additional fan, integrated in each power supply provides additional cooling for the whole system.

9 Rack rails and cable management

The sliding rail system for the R920 provides tool-less support for 4-post racks with square or unthreaded round mounting holes, including all generations of Dell racks. The sliding rail system also supports tool-less mounting in 4-post threaded racks.

In contrast to the R910 sliding rails that required the use of adapter brackets, the sliding rails for the R920 now offer native support for threaded-hole racks via the new ReadyRails II mounting interface. The rails ship in the tool-less mounting configuration but can be converted to the tool-less configuration very quickly and easily as shown in the figure below.

Figure 6. ReadyRails II mounting interface

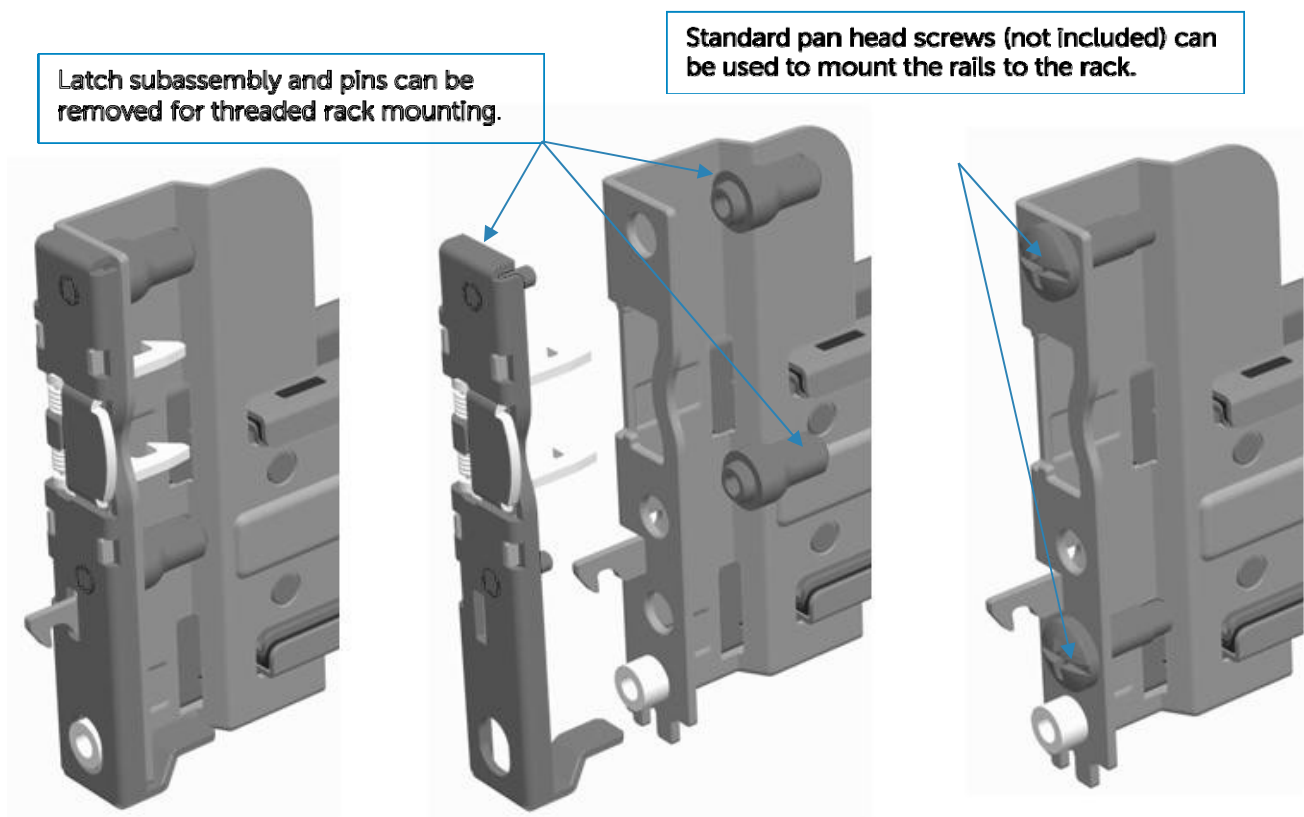

The optional cable management arm (CMA) or strain relief bar (SRB) that is provided with the CMA can be mounted to the sliding rails without the use of tools for fast and easy deployment. The CMA can be mounted on either the left or right side of the sliding rails.

NOTE: The R920 is **not** compatible with any other Dell rails or SRBs, including previous generation rails and SRBs. The R920 is compatible with R820, R720, R720xd and R520 CMAs.

Sliding rail system

Sliding rails allow the system to be fully extended out of the rack for service and are available with or without the optional cable management arm (CMA) and optional strain relief bar (provided with the CMA).

Figure 7. R920 Sliding Rails with optional CMA

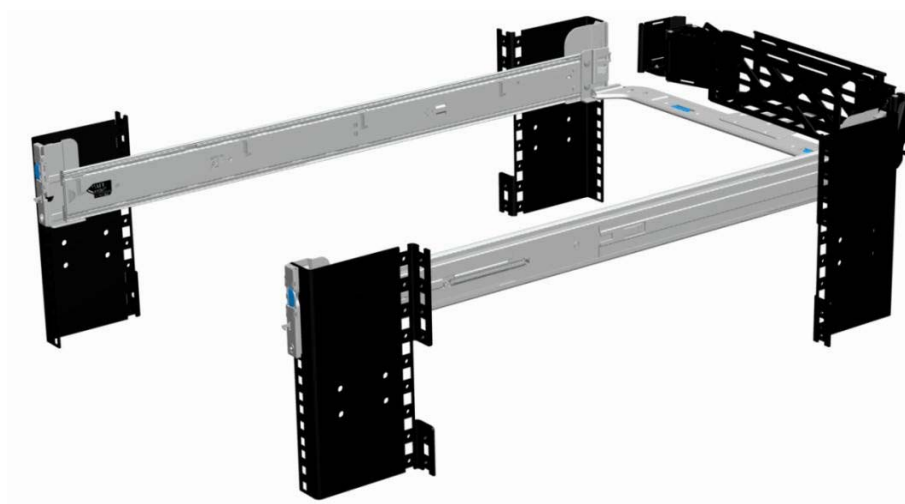

Sliding rails support 19" width tool-less mounting, EIA-310-E compliant square hole and unthreaded round hole 4-post racks. The rails also support tooled mounting in threaded hole 4-post racks, but the rails do not support mounting in 2-post (Telco) racks.

Table 15. PowerEdge R920 ReadyRails II

Rail Identifier	Mounting Interface	Rail Type	Rack Types Supported				
			4-Post			2-Post	
			Square	Round	Thread	Flush	Center
B8	ReadyRails II	Sliding	✓	✓	✓	✗	✗

Key factors impacting the fit of the rail in a rack include the spacing between the front and rear mounting flanges of the rack, the type and location of any equipment mounted in the back of the rack such as power distribution units (PDUs), and the overall depth of the rack.

Table 16. Supported racktypes

Product	Rail Identifier	Rail Type	Rail Adjustability Range (mm)						Rail Depth (mm)		
			Square		Round		Threaded		without CMA or SRB	with CMA	With SRB
			Min	Max	Min	Max	Min	Max			
R920	B8	Sliding	671	883	664	876	685	898	755	883	833

The adjustment range of the rails is a function of the type of rack in which they are being mounted. The minimum/maximum values listed above represent the allowable distance between the front and rear mounting flanges in the rack. Rail depth without the CMA or SRB represents the minimum depth of the rail with the outer CMA brackets removed (if applicable) as measured from the front mounting flanges of the rack.

For detailed information about static and sliding rails, see Additional specifications in Appendix A. For more information on installing the R920 in a rack, see the *Rack Installation Instructions* on Dell.com/Support/Manuals.

Cable Management Arm (CMA) and Strain Relief Bar (SRB)

The optional cable management arm (CMA) and strain relief bar (SRB) for the R920 organizes and secures the cords and cables exiting the back of the server. The CMA supports up to medium size cable loads and unfolds to allow the server to extend out of the rack without having to detach the cables. The SRB is a bar that supports large cable loads and also allows the server to extend out of the rack without having to detach the cables if cable service loops are created.

Key features of the R920 CMA include:

- ❑ Large U-shaped baskets to support small to medium cable loads
- ❑ Open vent pattern for optimal airflow
- ❑ Can be mounted on either side by simply swinging the spring-loaded brackets from one side to the other
- ❑ Utilizes hook-and-loop straps rather than plastic tie wraps to eliminate the risk of cable damage during cycling
- ❑ Includes a low profile fixed tray to both support and retain the CMA in its fully closed position
- ❑ Both the CMA and the tray mount without the use of tools via simple and intuitive snap-in designs

Key features of the R920 SRB include:

- ❑ Sturdy bar that supports large cable loads
- ❑ Controls stresses on connectors
- ❑ Power supplies are accessible without removing the SRB
- ❑ Utilizes hook-and-loop straps rather than plastic tie wraps to make securing cables quick and eliminates the risk of cable damage
- ❑ Cables can be segregated into discrete, purpose specific bundles
- ❑ Attaches to the rails without the use of tools via simple and intuitive latching design.

10 Operating systems and virtualization

The PowerEdge R920 supports a wide range of industry-standard operating systems.

Supported operating systems

Table 17 lists the primary operating systems supported on the R920. For the latest information on supported operating systems, see Dell.com/OSsupport.

Table 17. PowerEdge R920 supported operating systems

Operating system	Platform	Edition
	X32	
Red Hat® Enterprise Linux® 6.5	X64	N/A
Red Hat Enterprise Linux 7.0	X64	N/A
Red Hat Enterprise Linux 7.0 for HPC compute Node	X64	N/A
SLES 11 x86-64 SP2	X64	N/A
SLES 10 SP4 x86-64	X64	N/A
Red Hat Enterprise Virtualization 4.0	X64	N/A
Solaris	X64	N/A
		Standard
Microsoft® Windows Server® 2012	X64	Datacenter
		Standard
	X86	Enterprise
		Standard
Microsoft Windows Server 2008 SP2	X64 (with Hyper-V® enabled)	Enterprise Datacenter
Microsoft Windows Server 2008 R2 SP1	X64 (with Hyper-V role enabled)	Standard

Supported virtualization

The internal dual SD module enables Dell's unique Failsafe Virtualization architecture, ensuring uptime by providing failover capability for embedded hypervisors, such as VMware® vSphere® ESXi™. Table 18 highlights the virtualization support for the R920.

Table 18. Virtualization support

Operating systems	Install version	Factory options	Internal dual SD module install support	
VMware	vSphere v5.0	ESXi	DIB	Yes
	vSphere v5.0 U1	ESXi	DIB	Yes
	vSphere v5.1 U1	ESXi	DIB	Yes
	vSphere v5.1	ESXi	DIB	Yes
	vSphere v5.5	ESXi	DIB	Yes
Citrix	XenServer 6.2	N/A	DIB	Yes
Oracle	Virtual Machine 3.0			
Microsoft	Windows Server 2003 Virtual Machine only			

FI = factory install; DIB = drop in box

11 Dell OpenManage systems management

Whether your IT environment consists of a few servers or a few thousand servers, Dell OpenManage systems management solutions provide comprehensive management for evolving IT environments. OpenManage is based on open standards and provides agent-based and agent-free server lifecycle management functionality for Dell PowerEdge servers. OpenManage solutions help you automate and streamline essential hardware management tasks.

The advanced management capabilities of Dell OpenManage also integrates into offerings from other popular systems management solutions that you may already use, making Dell platforms easy to manage and deploy in any IT environment. This ensures your IT services are available when your business needs them. If you have already standardized on offerings from industry leaders, such as BMC Software, Microsoft, Symantec™, VMware, or other vendors, you can leverage OpenManage integration and connections developed for use with your existing systems management framework to efficiently manage Dell servers, storage, business-client PCs and network devices.

Start with a firm foundation for efficient hardware management using OpenManage tools, utilities and management consoles. OpenManage systems management solutions consist of a combination of embedded management features and software products that help you automate and simplify the entire server lifecycle: deploy, update, monitor and maintain. OpenManage solutions are innovatively designed for simplicity and ease of use to help you reduce complexity, save time, achieve efficiency, control costs and empower productivity.

Systems management solutions

Dell systems management solutions include a wide variety of tools, products, and services that enable you to leverage an existing systems management framework. As shown in Dell systems management solutions are centered around OpenManage server management, featuring iDRAC with Lifecycle Controller.

Figure 8. Dell systems management solutions



OpenManage systems management

The Dell OpenManage systems management portfolio includes powerful hardware and software management tools and consoles. OpenManage simplifies the lifecycle of deploying, updating, monitoring and maintaining your Dell PowerEdge servers.

iDRAC7 with Lifecycle Controller

The Integrated Dell Remote Access Controller 7 (iDRAC7) with Lifecycle Controller is the heart of Dell’s second generation of Dell PowerEdge server embedded management functionality. In addition to enabling agent-free management, iDRAC7 with Lifecycle Controller provides remote access to the system — whether or not there is a functioning operating system running on the server. These embedded features improve all aspects of a typical server lifecycle. Table 19 describes the functions and benefits of iDRAC7 with Lifecycle Controller.

Table 19. iDRAC7 with Lifecycle Controller functions and benefits

Feature	Function	Benefit
Out of band (OOB)	iDRAC7 offers real-time OOB discovery, inventory, deployment monitoring, alerting and updates for servers and internal storage	Manage servers independent of the OS type or status — even if an OS is not installed
Single code base	All server types have the same embedded management hardware and firmware	Simplified and consistent maintenance across server platforms

Feature	Function	Benefit
Dedicated GigE port (PowerEdge rack and tower systems)	Gigabit Ethernet replaces 10/100 on predecessor iDRAC6	Fast throughput for better performance; compatibility with setup for switches
Email alerts	Simplified, more informative, and expanded coverage than previous versions of iDRAC	More detail allows IT administrators to be more efficient in diagnosing and remediating an issue; alerts include a direct, embedded URL in the email notification to further speed resolution
vFlash media	Enabled with iDRAC7 Enterprise	Allows for use of a non-Dell SD card
Enhanced power management	Integration with Intel Node Manager provides data center level power monitoring and capping (requires iDRAC7 Enterprise)	Fine tune data center power policies, capping, and usage; report on historical power usage by rack, row or room using Power Center Manager (new)
Electronic licensing	Upgrades to iDRAC7 Express or iDRAC7 Enterprise by software licensing key and license portal (may require installation of hardware option for 300-500 series servers)	Digital license installed in factory; free 30-day trial versions are available; uses a license management portal versus paper-based licenses and simplifies license management. For most server models, embedded server management and electronic licensing enables feature enhancements that do not require installation of additional hardware or system downtime.

iDRAC feature comparison

iDRAC7 Enterprise is available for the PowerEdge R920, and Dell also offers an option of iDRAC7 Express. Table 20 shows a detailed feature comparison for iDRAC7 Enterprise and iDRAC7.

Table 20. Feature comparison for iDRAC7 Express and Enterprise

Feature (function)	Basic management	iDRAC7 Enterprise	iDRAC7 Express	iDRAC Express for blades
IPMI 2.0	∞	∞	∞	∞
Embedded diagnostics	∞	∞	∞	∞
Local OS install	∞	∞	∞	∞
Local updates	∞	∞	∞	∞
Driver pack	∞	∞	∞	∞
Shared NIC (LOM)	∞	∞	∞	∞
Local Configuration via USC	∞	∞	∞	∞
Remote update		∞	∞	∞

Feature (function)	Basic management	iDRAC7 Enterprise	iDRAC7 Express	iDRAC Express for blades
Power control		∞	∞	∞
Encryption		∞	∞	∞
Crash screen capture ¹		∞	∞	∞
IPv6		∞	∞	∞
Auto-discovery		∞	∞	∞
Auto-recovery		∞	∞	∞
Web GUI		∞	∞	∞
Remote CLI		∞	∞	∞
Local/SSH CLI		∞	∞	∞
Serial redirection		∞	∞	∞
Remote configuration		∞	∞	∞
Email alerts		∞	∞	∞
SNMP alerts		∞	∞	∞
Power monitoring		∞	∞	∞
Comprehensive monitoring		∞	∞	∞
Dedicated NIC 1Gbps		∞		∞
Part replacement		∞		
Backup and restore		∞		
Virtual console (4 user)		∞		∞
Virtual console chat		∞		
Virtual flash partitions		∞		
Virtual media		∞		∞
Virtual folders		∞		
Remote file share		∞		
Crash video playback		∞		
Boot record/playback		∞		
Power capping		∞		
Enterprise group power		∞		
Directory services (AD,		∞		
PK authentication		∞		
Two-factor authentication ²		∞		

Agent-based management

Most systems management solutions require pieces of software, called agents, to be installed on each node in order to be managed within the IT environment. Additionally, the same agent is often used as a local interface into the hardware health and may be accessed remotely as a management interface, typically referred to as a one-to-one interface. For customers that continue to use agent-based solutions, Dell provides OpenManage Server Administrator.

OpenManage Server Administrator

The Dell OpenManage Server Administrator (OMSA) agent gives you a comprehensive, one-to-one systems management solution for both local and remote servers and their storage. OMSA can help simplify single-server monitoring with a secure command-line interface (CLI) or Web-based management graphical user interface (GUI). It can also be used to view system configuration, inventory, health and performance.

Agent-free management

Because Dell PowerEdge servers have embedded server lifecycle management, in many cases, there is no need to install an OpenManage systems management software agent into the operating system of a Dell PowerEdge server. This greatly simplifies and streamlines the management footprint.

Dell consoles

The central console in a systems management solution is often referred to as the one-to-many console. The central console provides a rapid view and insight into the overall health of all systems in the IT environment. The Dell systems management portfolio includes several powerful consoles, depending upon your needs, including the following:

- **Dell OpenManage Essentials:** OpenManage Essentials (OME) is a systems management console that provides a comprehensive view of Dell systems, devices and components in an enterprise network. It is used to monitor Dell PowerEdge servers, EqualLogic™ and PowerVault™ storage and Dell Networking switches; to update and configure Dell servers; and to create asset reports. OpenManage Essentials also communicates health status alerts for Dell servers, storage, and network devices to the KACE™ K1000 service desk. OpenManage Essentials is available as a no-charge software download from Dell.com/Support.

OpenManage systems management tools and utilities

Dell OpenManage systems management tools and utilities consist of the following:

- **Dell Repository Manager:** The Dell Repository Manager (RM) is a standalone GUI-based productivity tool that helps simplify the process of managing downloads and baseline BIOS, firmware, and driver updates. Repository Manager can create deployment disks as well as create and manage customized repositories.
- **Dell OpenManage Server Update Utility:** The Dell Server Update Utility (SUU) is a DVD-based application for identifying and applying BIOS and firmware updates to your Dell PowerEdge servers.
- **Dell OpenManage Systems Build and Update Utility:** The Dell System Build and Update Utility (SBUU) provides one-to-one and one-to-many deployment and single-server update capabilities in the pre-operating system environment.

- **Dell Update Packages:** The Dell Update Packages (DUP) is a self-contained executable in a standard package format that updates a software element on a Dell server such as the BIOS, a driver, firmware and other software updates.
- **Dell OpenManage Deployment Toolkit:** The Dell OpenManage Deployment Toolkit (DTK) is a CLI-based tool that includes a set of utilities for configuring and deploying Dell PowerEdge systems, and can be used to build scripted, unattended OS installations to deploy large numbers of servers in a reliable fashion.
- **RACADM:** The RACADM command-line utility provides a scriptable interface that allows you to locally or remotely configure iDRAC7.
- **IPMITool:** IPMITool includes scriptable console application programs used to control and manage remote systems using the IPMI version 1.5 and later protocol.

Integration with third-party consoles

Dell OpenManage easily integrates with several leading third-party consoles, including:

- **Dell Server Management Pack Suite for Microsoft System Center Operations Manager (SCOM):** This suite of server management packs enables several functions through System Center Operations Manager, including in-band discovery and monitoring of racks and towers, out-of-band discovery and monitoring through iDRAC with Lifecycle Controller, as well as performance and advanced monitoring.
- **Dell Lifecycle Controller Integration (DLCI) for Microsoft System Center Configuration Manager (SCCM):** This pack contains Dell Lifecycle Controller Integration (DLCI), which integrates OpenManage functions in SCCM to manage the Dell PowerEdge servers, including auto-discovery, operating system deployment and configuration of hardware elements, (RAID, NIC, BIOS, iDRAC), OS and hypervisor agnostic updates, firmware management and system viewer utilities.
- **Dell Server PRO Management Pack for Microsoft System Center Virtual Machine Manager (SCVMM):** This pack manages Dell physical servers and hosts of virtual machines (VMs) by using Microsoft System Center Operations Manager/System Center Essentials (SCOM/SCE) and System Center Virtual Machine Manager (SCVMM). It provides guidance for remedial actions based on alerts to best manage virtual machines and handle the impacts appropriately.
- **OpenManage Integration for VMware vCenter:** This plug-in allows IT administrators to monitor, provision, and manage the physical PowerEdge server hardware and firmware from a dedicated Dell menu accessed through the VMware vCenter console using the same role-based access control model as vCenter, combining physical server management.
- **BMC Software:** Dell and BMC Software work together to simplify IT by ensuring tight integration between Dell server, storage, and network management functionality and the BMC Software process and data center automation products.

OpenManage integration and connections with third-party consoles

Dell OpenManage provides integrations and connections with many third-party consoles, including:

- **Dell OpenManage Connection for Computer Associates Network and Systems Management:** This connection allows you to monitor PowerEdge servers and PowerVault storage arrays from within the Computer Associates Network and Systems Management (CANSM) console.

- **Dell OpenManage Connection for HP Operations Manager:** This connection enables several functions through HP Operations Manager, including auto-grouping, SNMP trap reception, global health monitoring and a context-sensitive launch of OpenManage Server Administrator.
- **Dell OpenManage Connection for IBM Tivoli Netcool/OMNIBus:** This connection provides event monitoring capabilities to monitor Dell PowerEdge servers and Dell EqualLogic systems. It allows event monitoring, automatic event correlation and launching device consoles from the Netcool/OMNIBus console.

Dell server management operations

Dell OpenManage systems management is centered on automating the server management lifecycle — Deploy, Update, Monitor and Maintain. To manage an infrastructure properly and efficiently, you must perform all of these functions easily and quickly. iDRAC7 with Lifecycle Controller technology provides you with these intelligent capabilities embedded within the server infrastructure. This allows you to invest more time and energy on business improvements and less on maintenance. Figure 9 illustrates the various operations that can be performed during the server’s lifecycle.

Figure 9. Systems management server lifecycle



Table 21 lists the products that are available for one-to-one and one-to-many operations, and when they are used in the server’s lifecycle.

Table 21. One-to-one and one-to-many operations

Operation	One-to-one\	One-to-many	
Deploy	<ul style="list-style-type: none"> iDRAC7 with LifeCycle Controller GUI DTK SBUU 	<ul style="list-style-type: none"> Symantec Deployment Server OpenManage Integration for VMware vCenter KACE K1000 Appliance Lifecycle Controller Remote Services BMC BladeLogic integration with Lifecycle Controller 	<ul style="list-style-type: none"> Dell Server Deployment Pack (DSDP) for Microsoft System Center Configuration Manager and Dell Lifecycle Controller Integration (DLCI) for Microsoft System Center Configuration Manager
	<ul style="list-style-type: none"> iDRAC7 with LifeCycle Controller GUI Repository Manager DUP SUU SBUU OpenManage Integration for VMware vCenter 	<ul style="list-style-type: none"> Dell OpenManage Essentials Lifecycle Controller Remote Services 	<ul style="list-style-type: none"> Dell Update Catalogs for Microsoft System Center Configuration Manager Dell Lifecycle Controller Integration (DLCI) for Microsoft System Center Configuration Manager
Monitor	<ul style="list-style-type: none"> iDRAC7 with LifeCycle Controller OMSA 	<ul style="list-style-type: none"> Dell OpenManage Essentials BMC ProactiveNet Performance Management Integration with Lifecycle Controller Dell OpenManage Power Center 	<ul style="list-style-type: none"> OpenManage Integration for VMware vCenter BMC ProactiveNet Performance Management Integration with Lifecycle Controller Dell Server Management Pack Suite for Microsoft System Center Operations Manager (SCOM)
	<ul style="list-style-type: none"> iDRAC7 with Lifecycle Controller GUI 	<ul style="list-style-type: none"> Lifecycle Controller Remote Services 	<p>Remediate:</p> <ul style="list-style-type: none"> Dell Server PRO Management Pack for Microsoft System Center Virtual Machine Manager (SCVMM) <p>Replace parts:</p> <ul style="list-style-type: none"> Dell Lifecycle Controller Integration (DLCI) for Microsoft System Center Configuration Manager

For additional detailed information on Dell’s systems management portfolio, see the *Dell OpenManage Systems Management Overview Guide* on Dell.com/Support/Manuals.

Appendix A. Additional specifications

Chassis dimensions and weight

- 6.8 in (4U) height (172.6 mm)
- 18.99 in width (482.4 mm)
- 31.59 in depth (802.3 mm) with PSU and bezel
- 29.65 in depth (753 mm) without bezel

Dimensions (mm)									
Development Name	Model Number	Xa	Xb	Y	Za with bezel	Za without bezel	Zb*	Zc	Max Sys Wgt (Kg)
McCave	PE R910	482.4	422.0	172.6	35.0	20.4	699.0	753.0	47.6
Equinox	PE R920	482.4	422.0	172.6	35.0	20.4	726.2	767.3	59.0

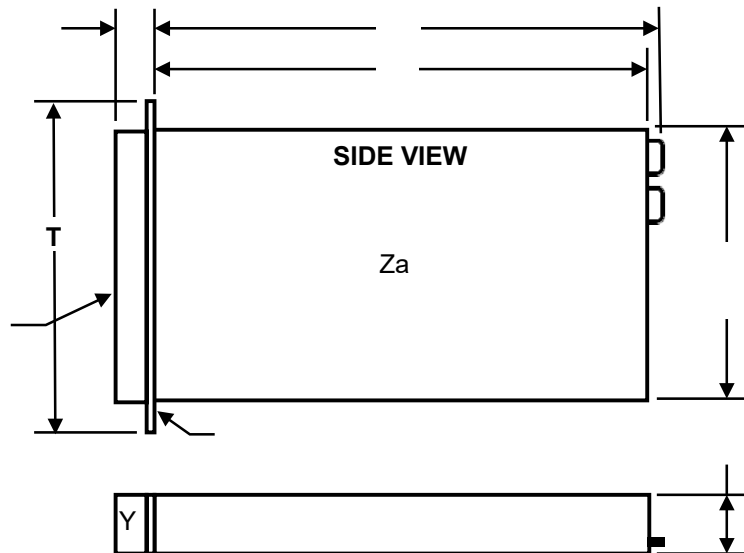

Video specifications

The R920 system Integrated Dell Remote Access Controller (iDRAC) incorporates an integrated video subsystem, connected to the Southbridge via PCI Express and internal PCIe Switch and PCIe to PCI bridge. The graphics controller is the 2D Matrox G200. The video frame buffer (16MB) is contained within the iDRAC RAM (256MB) device.

The R920 systems support the following 2D graphics video modes:

Table 22. Supported video modes

Resolution	Refresh rate (Hz)	Color depth (bit)
640 x 480	60, 70	8, 16, 32
800 x 600	60, 75, 85	8, 16, 32
1024 x 768	60, 75, 85	8, 16, 32

1152 x 864	60, 75, 85	8, 16, 32
1280 x 1024	60	8, 16, 32

Environmental specifications

Table 23 details the environmental specifications for the R920. For additional information about environmental measurements for specific system configurations, see [Dell.com/environmental_datasheets](https://www.dell.com/environmental_datasheets).

Table 23. Environmental specifications

Temperature

Continuous operation 10°C to 35°C at 10% to 80% relative humidity (RH), with 26 °C max dew point. De-rate maximum allowable dry bulb temperature at 1 °C/300m above 900m (1 °F per 550 ft).

Storage –40 °C to 65 °C (–40 °F to 149 °F) with a maximum temperature gradation of 20 °C per hour

Expanded operation When operating in the expanded temperature range, system performance may be impacted. When operating in the expanded temperature range, ambient temperature warnings may be reported on the LCD and in the System Event Log.

≤10% of annual operating hours: 5°C to 40°C at 5% to 85% RH with 26°C dew point.

≤1% of annual operating hours: –5°C to 45°C at 5% to 90% RH with 26°C dew point.

Outside the standard operating temperature (10 °C to 35 °C), the system can operate down to 5 °C or up to 40 °C for a maximum of 10% of its annual operating hours. For temperatures between 35 °C and 40 °C, de-rate maximum allowable dry bulb temperature by 1 °C per 175 m above 950 m (1 °F per 319 ft).

Outside the standard operating temperature (10 °C to 35 °C), the system can operate down to –5 °C or up to 45 °C for a maximum of 1% of its annual operating hours.

For temperatures between 40 °C and 45 °C, de-rate maximum allowable dry bulb temperature by 1 °C per 125 m above 950 m (1 °F per 228 ft).

Appendix B. Standards compliance

The PowerEdge R920 conforms to the industry standards listed in

Table 24. Industry standard documents

Standard	URL for information and specifications
ACPI Advance Configuration and Power Interface Specification, v2.0c	acpi.info
Ethernet IEEE 802.3-2005	standards.ieee.org/getieee802/802.3.html
HDG Hardware Design Guide Version 3.0 for Microsoft Windows Server	microsoft.com/whdc/system/platform/pcdesign/desguide/serv_erdg.msp
IPMI Intelligent Platform Management Interface, v2.0	intel.com/design/servers/ipmi
DDR3 Memory DDR3 SDRAM Specification, Rev. 3A	jedec.org/download/search/JESD79-3C.pdf
LPC Low Pin Count Interface Specification, Rev. 1.1	developer.intel.com/design/chipsets/industry/lpc.htm
PCI Express PCI Express Base Specification Rev. 2.0 and 3.0	pcisig.com/specifications/pciexpress
SAS Serial Attached SCSI, v1.1	t10.org
SATA Serial ATA Rev. 2.6; SATA II, SATA 1.0a Extensions, Rev. 1.2	sata-io.org
SMBIOS System Management BIOS Reference Specification, v2.7	dmtf.org/standards/smbios/
TPM Trusted Platform Module Specification, v1.2	trustedcomputinggroup.org
UEFI Unified Extensible Firmware Interface Specification, v2.1	uefi.org/specs
USB Universal Serial Bus Specification, Rev. 2.0	usb.org/developers/docs

Windows Logo

Windows Logo Program System and Device
Requirements, v3.10

microsoft.com/whdc/winlogo/hwrequirements.msp

Appendix C. Additional resources

Table 25 provides a list of documents and websites that provide for more information on the R920

Table 25. Resource documents and websites

Resource	Description of content	Location
PowerEdge R920 Owner's Manual	This manual, available in PDF format, provides the following information: <ul style="list-style-type: none">• Chassis features• System Setup program• System messages• System codes and indicators• System BIOS• Remove and replace procedures• Troubleshooting• Diagnostics• Jumpers and connectors	Dell.com/Support/Manuals
PowerEdge R920 Getting Started Guide	This guide ships with the system, and is also available in PDF format. This guide provides the following information: <ul style="list-style-type: none">• Initial setup steps• Key system features• Technical specifications	Dell.com/Support/Manuals
Rack Installation Instructions	This document ships with the rack kits, and provides instructions for installing a server in a rack.	Dell.com/Support/Manuals
Cable Management Arm Installation Instructions	This document ships with the rack kits, and provides instructions for installing a cable management arm on a rack.	Dell.com/Support/Manuals
Information Update	This document ships with the system, is also available in PDF format online, and provides information on system updates.	Dell.com/Support/Manuals
System Information Label	The system information label documents the system board layout and system jumper settings. Text is minimized due to space limitations and translation considerations. The label size is standardized across platforms.	Inside the system chassis cover
Quick Resource Locator (QRL)	This code on the chassis can be scanned by a phone application to access additional information and resources for the server, including videos, reference materials, service tag information, and Dell contact information.	Inside the system chassis cover

Energy Smart Solution Advisor	The Dell online Energy Smart Solution Advisor (ESSA) enables easier and more meaningful estimates to help you determine the most efficient configuration possible. Use ESSA to calculate the power consumption of your hardware, power infrastructure, and storage.	Dell.com/ESSA
Power and cooling technologies	Provides details for improving energy efficiency in the data center.	Dell.com/PNC
Energy management	Provides information on Dell's Fresh Air cooling solutions.	Dell.com/FreshAir
Operating system matrix for Dell PowerEdge systems	Provides updated information on which operating systems are available on which PowerEdge systems.	Dell.com/OSsupport
Processor and chipset	Provides more information about the R920 processors and chipset.	Intel.com
Dell PowerEdge RAID controllers	Provides more information on Dell PowerEdge RAID controllers (PERC).	Dell.com/PERC
Power distribution unit	Provides help selecting a rack-based power distribution unit (rPDU).	DellPDU.com
Uninterruptible power supply	Provides help selecting a UPS model.	DellUPS.com
Volatility information	Contact your Dell sales representative.	Dell.com
Dell Enterprise Acoustics	White paper that explores the mechanisms of, people's reaction to, language of, and Dell's work to control noise from Enterprise products.	Dell.com/downloads/global/products/pedge/en/acoustic-al-education-dell-enterprise-white-paper.pdf

Appendix D. Block diagram

Figure 10. R920 block diagram

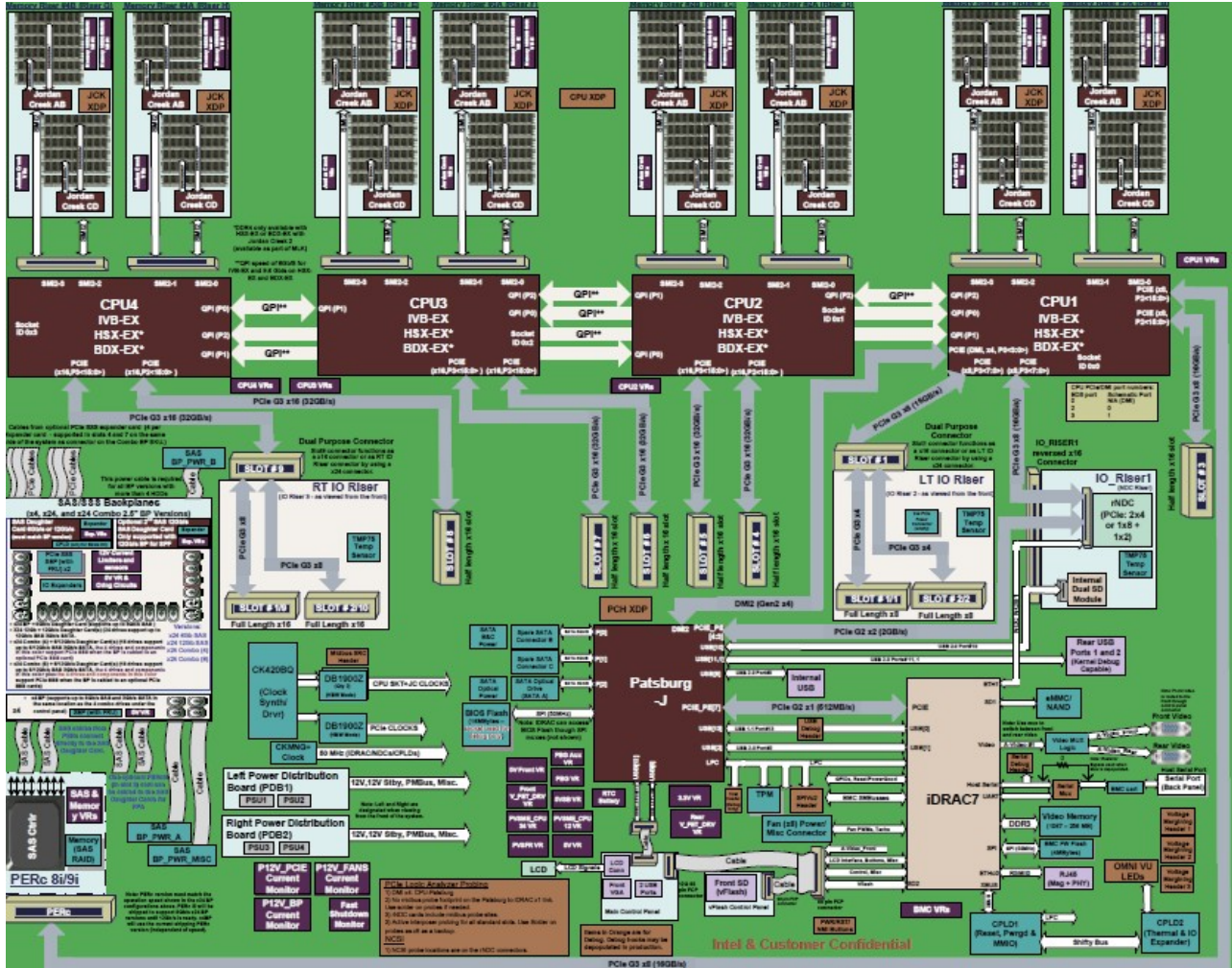

Appendix E. Dell Global Support and Deployment Services

Dell Global Services include a wide, customizable range of service choices to simplify the assessment, design, implementation, management and maintenance of your IT environment and to help you transition from platform to platform. Depending on your current business requirements and the level of service you want, we can provide you with factory, on-site, remote, modular and specialized services that fit your needs and budget. We'll help you with a little or a lot — your choice — and provide you with access to our global resources.

Server deployment services

Our server deployment services can maximize the value of your servers quickly using our expert server deployment engineers. With more than 10,000 server deployment projects each year, we have experience, best practices and comprehensive deployment tools to install, configure and integrate your new solution optimally and correctly. Our deployment experts will assess your environment and understand your goals, then design and integrate your server solution for you.

Server Deployment Capabilities

	Server Installation	Server Integration
Place single server in target workspace	✓	
Rack, cable, and label servers	✓	
Install image	✓	
Connect to network	✓	✓
Test and validate connection	✓	✓
Install operating system		✓
Install applications		✓
Perform advanced configuration services		✓
Remote configuration services		✓
Virtualization		✓
Converged infrastructure		✓
Test and validate data center integration		✓

We are also experts at rack integration and solutions such as HPC, Openstack and Hadoop.

Dell's server deployment services help you optimize your server configurations and quickly and correctly install and integrate your solution — so you can be up and running faster with minimal disruption to day-to-day business operations. Our deployment experts provide:

- Single point of project management contact from beginning to end
- Evaluation of your environment with a detailed project plan
- Optimized configurations for your workloads and user environment
- Personalized documentation and orientation

Remote consulting services

When you are in the final stages of the PowerEdge server implementation, you can rely on Dell Remote Consulting and our certified technical experts to help you optimize your configuration with best practices for your software, virtualization, server, storage, networking and systems management.

Data migration service

Protect your business and data with our single point of contact to manage your data migration project. Your project manager will work with our experienced team of experts to create your plan using industry leading tools and proven processes based on global best practices to migrate your existing files and data, so your business gets up and running quickly and smoothly.

ProSupport Enterprise Suite

With Dell ProSupport Services, we can help you keep your operation running smoothly, so you can focus on running your business. We'll help you maintain peak performance and availability of your most essential workloads.

Dell ProSupport is a suite of support services that enable you to build the solution that's right for your organization. Choose support models based on how you use technology and where you want to allocate resources. From the desktop to the data center, address everyday IT challenges, such as unplanned downtime, mission-critical needs, data and asset protection, support planning, resource allocation, software application management and more. Optimize your IT resources by choosing the right support model.

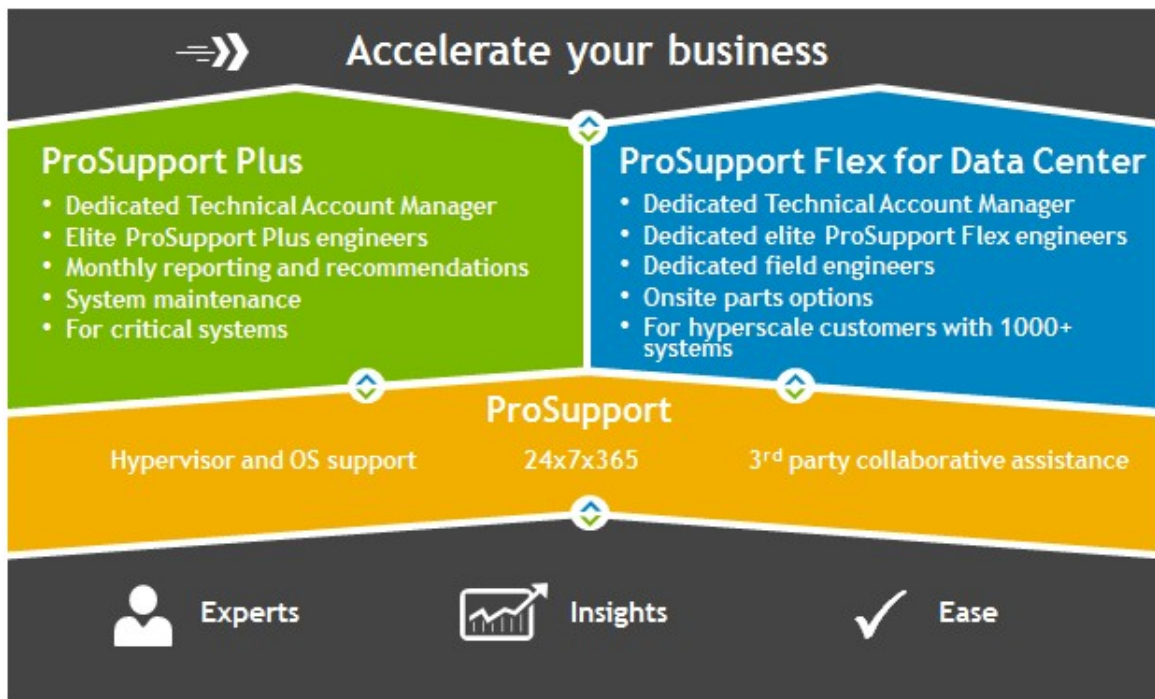

ProSupport Plus for business-critical servers

When you purchase your PowerEdge server, we recommend ProSupport Plus, our proactive and preventative support for your business-critical systems. Dell ProSupport Plus provides you with all the benefits of ProSupport, plus access to a dedicated Technical Account Manager and our elite

ProSupport Plus engineers. ProSupport Plus gives you quick and efficient resolutions, working along with our SupportAssist technology that enables us to get ahead of issues in your environment before they become problems.

ProSupport

Our ProSupport service offers highly trained experts around the clock and around the globe to address your IT needs. We'll help you minimize disruptions and maximize availability of your PowerEdge server workloads with

- 24x7x365 access to certified hardware experts
- Collaborative support assistance with over 195 third-party vendors
- Hypervisor and operating system support
- On-site parts and labor response options including next business day or four-hour mission critical

ProSupport Flex for Data Center

Dell ProSupport Flex for Data Center offers flexible site-wide support for hyperscale data centers with more than 1,000 assets. Built on standard Dell ProSupport components, Flex for Data Center leverages our global scale while being tailored to suit your needs. While not for everyone, it offers a flexible solution for those with large and complex environments.

When you choose Dell ProSupport Flex for Data Center, you'll get:

- Enterprise-wide support that covers your entire data center
- A dedicated Technical Account Manager with remote, on-site, part-time and full-time options
- Dedicated elite ProSupport Flex technical and field engineers who are trained on your environment and configurations
- Flexible onsite support and parts options that fit your operational model
- A tailored support plan for your operations staff

ProSupport Enterprise Suite comparison

	ProSupport	ProSupport Plus	ProSupport Flex for Data Center
Technical support access	24x7	24x7	24x7
Parts and labor response	NBD or Mission Critical	NBD or Mission Critical	Flexible
TechDirect online cases and dispatch	✓	✓	✓
SupportAssist remote monitoring	✓	✓	✓
Dispatch monitoring and crisis management	✓	✓	✓
Escalation management	✓	✓	✓
Hypervisor and OS support	✓	✓	✓
Collaborative 3 rd party software support	✓	✓	✓
SupportAssist proactive resolution	✓	✓	✓
Direct access to elite ProSupport Plus engineers		✓	✓
Dedicated Technical Account Manager		✓	✓
Monthly health check and performance recommendations		✓	✓
Monthly contract renewal and service history reporting		✓	✓
System maintenance (as needed)		✓	✓
Dedicated technical and field support teams			✓
Site-wide entitlement and contract			✓
Case management API			✓

Additional professional services

Dell Training Services

Dell Education Services offers PowerEdge server training courses designed to help you achieve more with your hardware investment. The curriculum is designed in conjunction with the server development team, as well as Dell's technical support team, to ensure that the training delivers the information and practical, hands-on skills you and your team need to confidently manage and maintain your Dell Server solution. To learn more or register for a class today, visit learndell.com/server.

Dell IT Consulting Services

Dell Global Infrastructure Consulting Services use skilled solution architects, innovative tools, automated analysis and Dell's intellectual property to give you rapid insight into the root causes of unnecessary complexity. We seek better answers than traditional service models, and our strategy is to help you quickly identify high-impact, short-duration projects that deliver return on investment (ROI) and free up resources. The results are practical, action-oriented plans with specific, predictable, measurable outcomes. From Data Center optimization to server virtualization to Systems Management, our consulting services can help you build a more efficient enterprise.

Dell Managed Services

Dell Managed Services are a modular set of lifecycle services designed to help you automate and centrally configure, deploy and manage your day-to-day data center operations. These services extend your existing on-premise IT infrastructure with off-premise cloud services designed to better address challenges with mobility, highly distributed organizations, security, compliance, business continuity and disaster preparedness.

