

DELLTM

OPTIPLX XE

TECHNICAL GUIDEBOOK

INSIDE THE OPTIPLX XE

OVERVIEW

Desktop Computer (DT) View	3
Desktop Back Panel Connectors	4
Desktop System Board	5
Small Form Factor Computer (SFF) View	6
Small Form Factor Back Panel Connectors	7
Small Form Factor System Board	8

MARKETING SYSTEM CONFIGURATIONS

Operating System, Chipset	9
Processor, Advanced System Manageability Modes, System Monitoring Options	10
Memory	11
Drives and Removable Storage	12-13
System Board Connectors, Graphics/Video Controller	13
External Ports/Connectors	14
Communications—Integrated LAN, Wireless, Audio and Speakers, Keyboard and Mouse, Security	15
Security, Service and Support, Software, System Accessories	16

DETAILED ENGINEERING SPECIFICATIONS

System Dimensions (Physical)	17
System Board Connector Maximum Allowable Dimensions	18
System Level Environmental and Operating Conditions	19
Power, Compliance	20
Audio	21
Communications	22-24
Graphics/Video Controller	24-26
Hard Drives	26-32
Optical Drive	33-34
BIOS Defaults	35
Chassis Enclosure and Ventilation Requirements	36
Acoustic Noise Emission Information	37-38

DESKTOP COMPUTER (DT) VIEW

Front and Back View

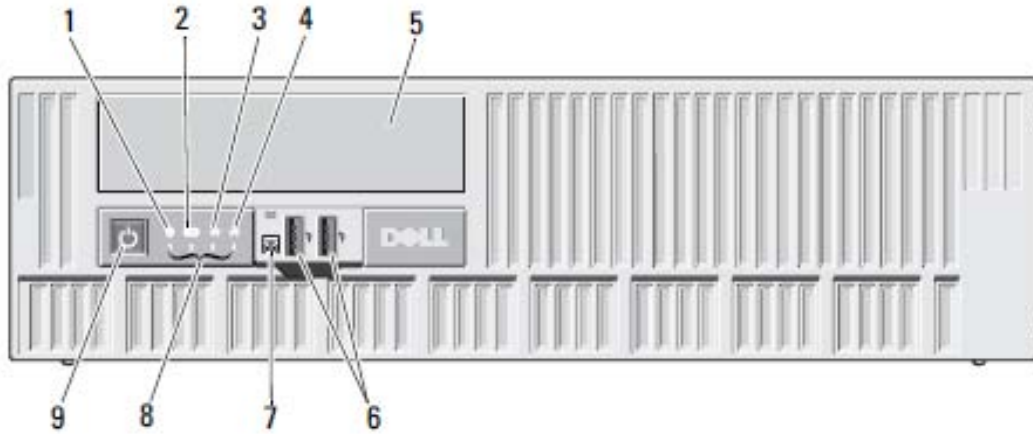

FRONT VIEW

1	Drive activity light	4	Network activity light 2	7	External power button connector
2	Wi-Fi activity light	5	DVD drive bay	8	Diagnostic Lights (4)
3	Network activity light 1	6	USB 2.0 connectors (2)	9	Power button, power light

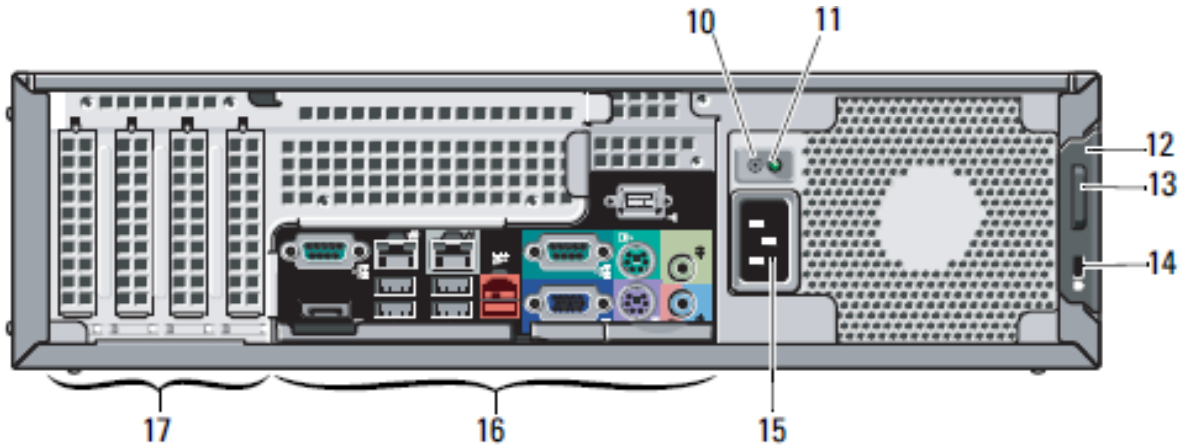

BACK VIEW

10	Power supply diagnostic button	13	Padlock ring	16	Back panel connectors
11	Power supply diagnostic light	14	Security cable slot	17	Expansion card slots (4)
12	Cover release latch	15	Power cable connector		

DT Back Panel Connectors

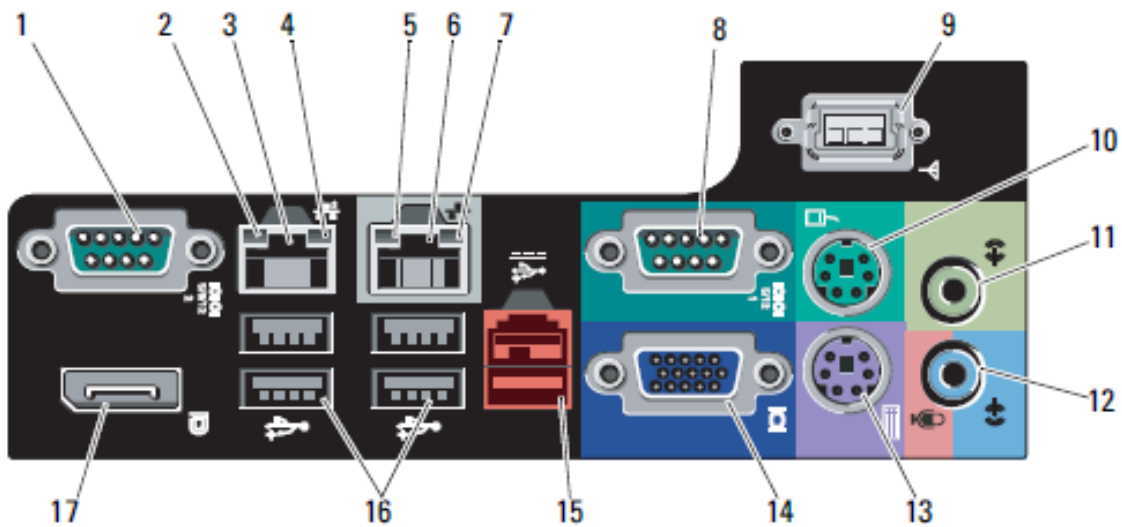

BACK PANEL CONNECTORS

1	Serial Connector 1	10	PS/2 Mouse Connector
2	Link Integrity Light 2	11	Line-Out Connector
3	Network Adapter Connector 2	12	Line-In/Mic Connector
4	Network Activity Light 2	13	PS/2 Keyboard Connector
5	Link Integrity Light 1	14	VGA Connector
6	Network Adapter Connector 1 (TruManage Capability)	15	24V Powered USB Connector
7	Network Activity Light 1	16	USB 2.0 Connectors (4)
8	Serial Connector 2	17	DisplayPort
9	Wi-Fi Connector		

DT System Board

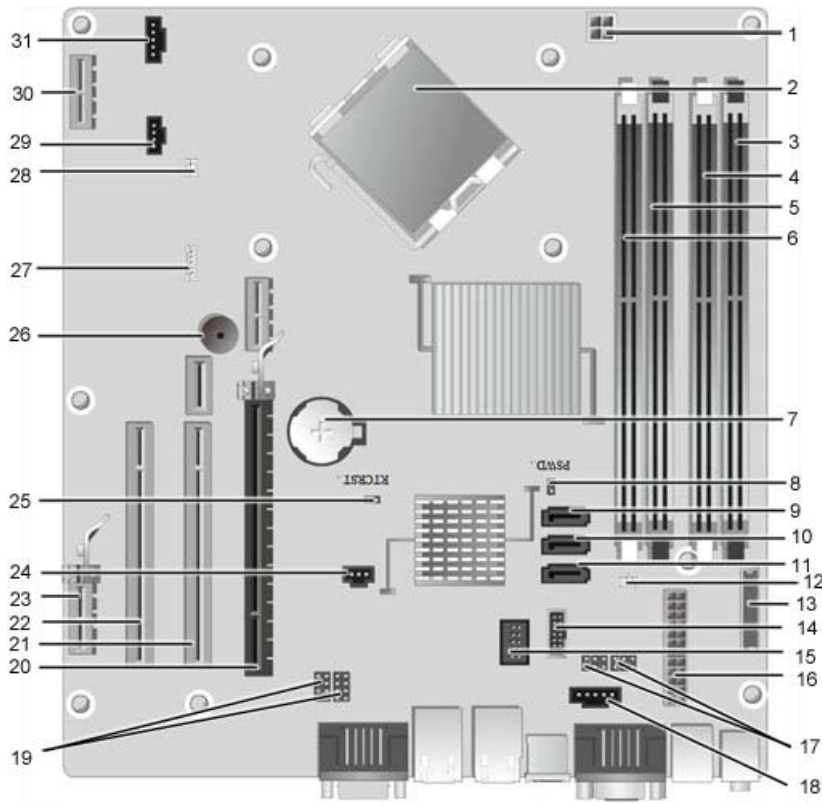

1	Processor power connector (12VPOWER)	17	Serial Port Jumper (J3 & J4)
2	Processor connector (CPU)	18	Power connector (24V POWER)
3	Memory module connectors (DIMM_4)	19	Serial Port Jumper (J1 & J2)
4	Memory module connectors (DIMM_2)	20	PCI Express x16 card connector(SLOT1)
5	Memory module connectors (DIMM_3)	21	PCI card connectors (SLOT2)
6	Memory module connectors (DIMM_1)	22	PCI card connectors (SLOT3)
7	Battery socket (BATTERY)	23	PCI Express x1 card connector(SLOT4)
8	Password jumper (PSWD)	24	Intruder connector (INTRUDER)
9	SATA drive connectors (SATA0)	25	RTC reset jumper (RTCIRST)
10	SATA drive connectors (SATA1)	26	Internal buzzer (SPKR)
11	SATA drive connectors (SATA2)	27	Speaker connector (INT_SPKR)
12	Thermal sensor connector (rear)	28	Thermal Sensor connector (front)
13	Front-panel connector (FRONTPANEL)	29	Fan connector (FAN_HDD)
14	External Power USB connector	30	Connector for optional wireless card
15	Internal USB connector	31	Fan connector (FAN_CPU)
16	Power connector (POWER)		

Small Form Factor (SFF) Computer View

Front and Back View

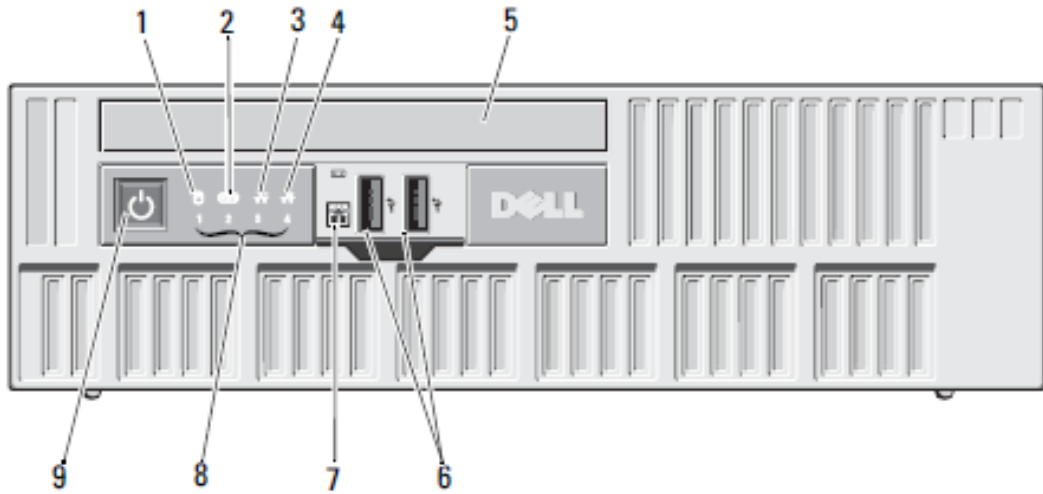

FRONT VIEW

1	Drive activity light	4	Network activity light 2	7	External power button connector
2	Wi-Fi activity light	5	DVD drive bay	8	Diagnostic Lights (4)
3	Network activity light 1	6	USB 2.0 connectors (2)	9	Power button, power light

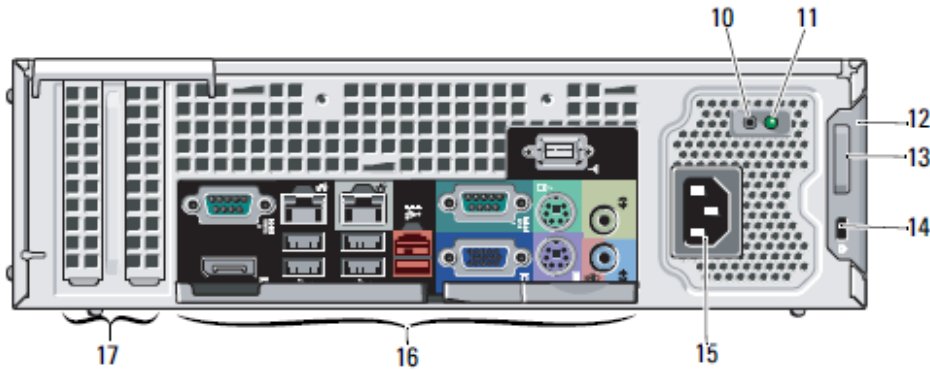

BACK VIEW

10	Power supply diagnostic button	13	Padlock ring	16	Back panel connectors
11	Power supply diagnostic light	14	Security cable slot	17	Expansion card slots (2)
12	Cover release latch	15	Power cable connector		

SFF Back Panel Connectors

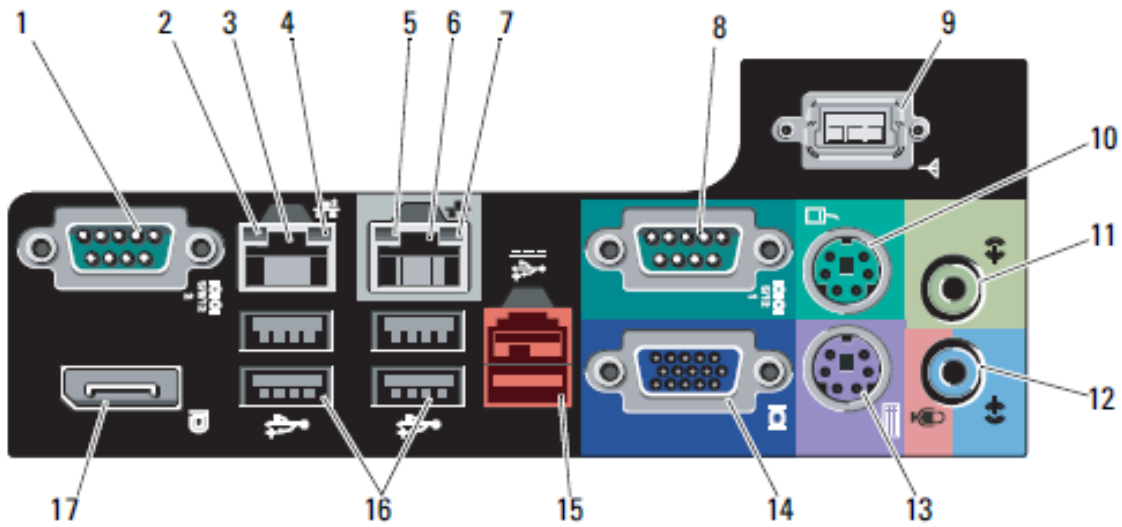

BACK PANEL CONNECTORS

1	Serial Connector 1	10	PS/2 Mouse Connector
2	Link Integrity Light 2	11	Line-Out Connector
3	Network Adapter Connector 2	12	Line-In/Mic Connector
4	Network Activity Light 2	13	PS/2 Keyboard Connector
5	Link Integrity Light 1	14	VGA Connector
6	Network Adapter Connector 1 (TruManage Capability)	15	24V Powered USB Connector
7	Network Activity Light 1	16	USB 2.0 Connectors (4)
8	Serial Connector 2	17	DisplayPort
9	Wi-Fi Connector		

SFF System Board

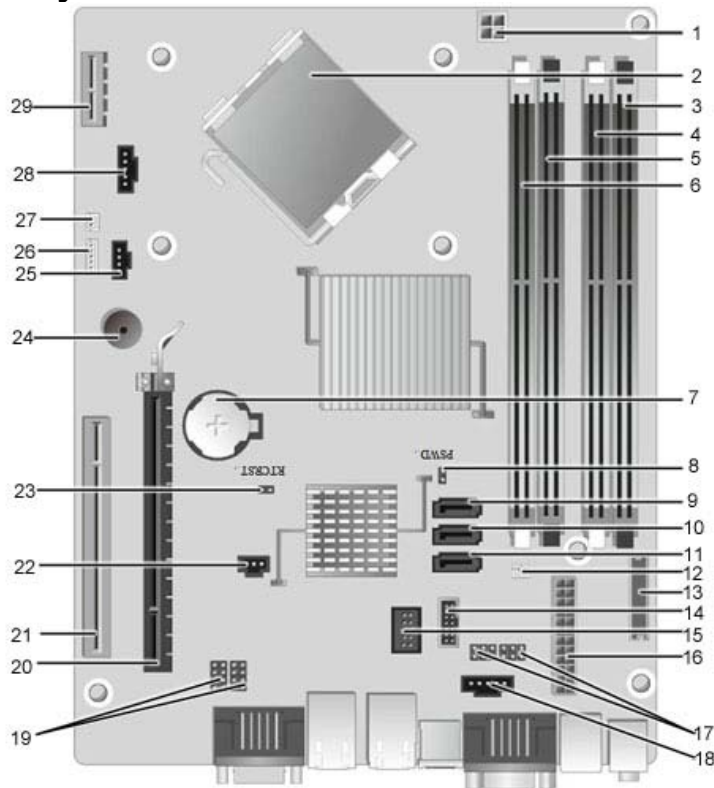

1	Processor power connector (12VPOWER)	16	Power connector (POWER)
2	Processor connector (CPU)	17	Serial Port Jumper (J3 & J4)
3	Memory module connectors (DIMM_4)	18	Power connector (24V POWER)
4	Memory module connectors (DIMM_2)	19	Serial Port Jumper (J1 & J2)
5	Memory module connectors (DIMM_3)	20	PCI Express x16 card connector(SLOT1)
6	Memory module connectors (DIMM_1)	21	PCI card connectors (SLOT2) - half height
7	Battery socket (BATTERY)	22	Intruder connector (INTRUDER)
8	Password jumper (PSWD)	23	RTC reset jumper (RTCST)
9	SATA drive connectors (SATA0)	24	Internal buzzer (SPKR)
10	SATA drive connectors (SATA1)	25	Fan connector (FAN_HDD)
11	SATA drive connectors (SATA2)	26	Speaker connector (INT_SPKR)
12	Thermal sensor connector (rear)	27	Thermal Sensor connector (front)
13	Front-panel connector (FRONTPANEL)	28	Fan connector (FAN_CPU)
14	External Power USB connector	29	Connector for optional wireless card
15	Internal USB connector		

Marketing System Configurations

NOTE: Offerings may vary by region. For more information regarding the configuration of your computer, click [Start](#)  [Help and Support](#) and select the option to view information about your computer.

Operating System

NOTE: One of the following Operating Systems will be preinstalled.

	DT	SFF
Windows 7® operating system	Microsoft® Windows 7® Ultimate (32/64 bit) Windows® 7 Professional (32/64 bit) Microsoft® Windows® 7 Home Premium (32-bit) Microsoft® Windows® 7 Home Basic(select countries)	
Windows Vista® operating system	Microsoft® Windows Vista® Business (32/64 bit) Microsoft® Windows Vista® Home Basic Microsoft® Windows Vista® Business Downgrade via Windows® 7 Professional	
Windows XP® operating system	Microsoft® Windows® XP Professional Downgrade via Windows® 7 Ultimate or Professional Microsoft® Windows XP® Professional Downgrade via Windows Vista® Business Microsoft® Windows® XP Home (China only)	
Other	Microsoft® Windows® Embedded POSReady 2009 Ubuntu® Linux® (China only) FreeDOS for N-series	
OS Media Support	X	X

Chipset

NOTE: The OptiPlex XE uses a Chipset from Intel's long lifecycle Embedded Roadmap

	DT	SFF
Chipset	Intel Q45 Express Chipset w/ICH10DO	
Non-volatile memory on chipset		
BIOS Configuration SPI (Serial Peripheral Interface)	16Mbit (2MB) located at SPI_FLASH on chipset	
NIC EEPROM	5761—8Mbit, 57780—OTP	

Processor

NOTES:

- The OptiPlex XE uses CPUs from Intel's long lifecycle Embedded Roadmap
- Processor numbers are not a measure of performance.
- Processor availability subject to change and may vary by region/country

	DT	SFF
Intel® Core™ 2 Duo and Pentium® Dual Core Processors		
Intel® Core™ 2 Duo E7400/2.83GHz, 3M, 1066FSB	X	X
Intel® Pentium® Dual-Core E5300/2.60GHz, 2M, 800FSB	X	X
Intel® Celeron® Processors		
Intel® Celeron® 440/2.0GHz, 512K, 800FSB	X	X

Advanced System Manageability Modes

NOTE: Hardware management mode options allow you to select the right systems management feature support for your enterprise. Dell's innovative approach to scalable remote client management offers you a choice of built-in hardware management capabilities across platform offerings.

The latest generation of Broadcom® TruManage™ technology provides the capability to manage your install base of systems regardless of the power or O/S state of the system.

This functionality allows IT to address many issues remotely rather than having to physically visit systems.

The OptiPlex™ XE supports Broadcom® TruManage™ technology which supports the following features:

BIOS Management, asset reporting, remote troubleshooting and repair, power on for remote patching/updating.

	DT	SFF
Broadcom TruManage Systems Management Ready	X	X

System Monitoring Options

NOTES:

- The Dell Watchdog Timer is hardware based with a software user interface
- The Dell Watchdog Timer must be enabled through the Dell factory; cannot be installed after purchase.
- Once enabled, the end user has the ability to configure the desired system response taken in the event a system hangs during boot or O/S load, or if an application does not respond in the specified amount of time.

	DT	SFF
Dell Watchdog Timer	Optional via factory installation only	

Memory

NOTES:

- Your computer supports a maximum of 8GB of memory when you use four 2GB DIMMs; however, 32-bit operating systems, such as the 32-bit version of Microsoft® Windows® XP, can only use a maximum of 4 GB of address space. Moreover, certain components within the computer require address space in the 4GB range. Any address space reserved for these components cannot be used by computer memory; therefore, the amount of memory available to the operating system is less than 4GB.
- The entire 8GB memory range is available to 64-bit operating systems.
- Memory modules should be installed in pairs of matched memory size, speed, and technology. If the memory modules are not installed in matched pairs, the computer will continue to operate, but with a slight reduction in performance.

	DT	SFF
Type: DDR3 Synch DRAM Non-ECC Memory	1066MHz or 1333MHz	
DIMM Slots	4	4
DIMM Capacities	Up to 2GB	Up to 2GB
Minimum Memory	1GB	1GB
1066MHz/1333MHz Memory configurations		
8GB ¹ DDR3 Non-ECC SDRAM, 1066MHz/1333MHz, (4 DIMM)	X	X
4GB ¹ DDR3 Non-ECC SDRAM, 1066MHz/1333MHz, (4 DIMM)	X	X
4GB ¹ DDR3 Non-ECC SDRAM, 1066MHz/1333MHz, (2 DIMM)	X	X
3GB DDR3 Non-ECC SDRAM, 1066MHz/1333MHz, (3 DIMM)	X	X
3GB DDR3 Non-ECC SDRAM, 1066MHz/1333MHz, (2 DIMM)	X	X
2GB DDR3 Non-ECC SDRAM, 1066MHz/1333MHz, (2 DIMM)	X	X
2GB DDR3 Non-ECC SDRAM, 1066MHz/1333MHz, (1 DIMM)	X	X
1GB DDR3 Non-ECC SDRAM, 1066MHz/1333MHz, (1 DIMM)	X	X

¹The total amount of available memory will be less than 4GB. The amount less depends on the actual system configuration. To fully utilize 4GB or more of memory requires a 64-bit enabled processor and 64-bit operating system.

Drives and Removable Storage

	DT	SFF
Bays:		
5.25-inch bay (for External Optical)	1	1 (slimline)
3.5" Hard Drives Supported (Internal)	2	1
2.5" Hard Drives Supported (Internal)	1	2
Interface:		
SATA	3	3
3.5" Hard Drives:		
500GB ² SATA 7200 RPM HDD	X	X
320GB ² SATA 7200 RPM HDD	X	X
250GB ² SATA 7200 RPM HDD	X	X
160GB ² SATA 7200 RPM HDD	X	X
2.5" Hard Drives		
128GB ² SATA Solid State HDD	X	X
64GB ² SATA Solid State HDD	X	X
250GB ² SATA 7200 RPM FIPS Encrypted HDD	X	X
250GB ² SATA 7200 RPM HDD	X	X
160GB ² SATA 7200 RPM HDD	X	X
RAID 1 Data Protection: (includes two matching capacity/speed hard drives)		
500GB ² SATA 7200 RPM HDD (3.5")	X	
320GB ² SATA 7200 RPM HDD (3.5")	X	
250GB ² SATA 7200 RPM HDD (3.5")	X	
160GB ² SATA 7200 RPM HDD (3.5")	X	
250GB ² SATA 7200 RPM HDD (2.5")		X
160GB ² SATA 7200 RPM HDD (2.5")		X
RAID 0 Performance: (includes two matching capacity/speed hard drives)		
1TB ² SATA 7200 RPM HDD (3.5")	X	
500GB ² SATA 7200 RPM HDD (3.5")	X	
320GB ² SATA 7200 RPM HDD (3.5")	X	
500GB ² SATA 7200 RPM HDD (2.5")		X

	DT	SFF
320GB ² SATA 7200 RPM HDD (2.5")		X
Optical Drive: (SFF requires a slimline optical drive)		
DVD+/-RW ³	SATA 1.5Gbit/s	SATA 1.5Gbit/s
DVD-ROM ⁴	SATA 1.5Gbit/s	SATA 1.5Gbit/s

² For hard drives, GB means 1 billion bytes; actual capacity varies with preloaded material and operating environment and will be less.

³ Discs burned with this drive may not be compatible with some existing drives and players; using DVD+R media provides maximum compatibility.

⁴ DVD-ROM drives may have write-capable hardware that has been disabled via firmware modifications.

System Board Connectors

NOTE: See Detailed Engineering Specifications for maximum card dimensions support.

	DT	SFF
PCI Slot(s): number of	2	1
PCIe x16 Slot⁵: number of	1	1
PCIe x1 Slot: number of	1	0
Serial ATA (SATA)	3	3

⁵ Use of PCIe x16 slot (including use of the riser) disables on-board DisplayPort functionality. Discrete graphics card or on-board VGA port can be utilized for graphics if PCIe x16 slot is occupied.

Graphics/Video Controller

NOTE: DT supports low profile card or full height card with optional riser. SFF supports low profile card.

	DT	SFF
Integrated Intel GMA 4500	Integrated on system board with specific processors	
Enhanced Graphic/Video Options		
512MB AMD RADEON HD4550 Graphics, DP, DVI	Optional full height or low profile card	

External Ports/Connectors

NOTE: DT supports low profile cards or full height cards with optional riser. SFF supports low profile cards.

See chassis diagrams section for port/connector locations

	DT	SFF
USB 2.0	2 front, 4 rear, 2 internal	
24V Powered USB 2.0	1 rear	
Serial	2 rear with option for powered	
Network Connector (RJ-45)	2 rear	
PS/2	2 rear	
Wireless	Optional via add-in card	
Routing for external power	1 front	
Video:		
VGA	1 rear	
Display Port	1 rear	
DVI-D	Optional via add-in card or DP-to-DVI adapter	
Audio:		
Line in/microphone	1 rear	
Line out	1 rear	
Risers: (replaces PCI slot and PCIe x16 slot on DT system board)		
Combo full height riser with 1 PCI and 1 PCIe x16 connector	X	
Dual full height riser with 2 PCI connectors	X	
Add-In Port Cards:		
3 Port 12V Powered USB PCI Card	Optional full height card	
2 Port 12V Powered USB PCI Card	Optional low profile card	
2 Port Powered Serial PCIe x1 card	Optional low profile card	

Communications – Integrated LAN

	DT	SFF
Broadcom® BCM5761 NetXtreme®	Integrated on system board	
Broadcom® BCM57780 NetLink® 10/100/1000	Integrated on system board	

Communications – Wireless

	DT	SFF
Dell Wireless 1520 PCIe WLAN card (802.11n)	Optional via add-in card	

Audio and Speakers

	DT	SFF
Realtek ALC269 VB	Integrated on system board	
Internal Dell Business Audio Speaker	Optional	
Dell AX510/AX510PA Flat Panel Soundbar Speakers	Optional	

Keyboard and Mouse

	DT	SFF
Dell USB Keyboard	Optional	
Dell USB QuietKey Keyboard with optional palmrest	Optional	
Dell USB Multimedia Pro Keyboard	Optional	
Dell USB Optical Mouse	Optional	
Dell Laser Mouse	Optional	

Security

	DT	SFF
Chassis Intrusion Switch	Standard	
Chassis lock slot and loop support	Standard	

Service and Support

NOTE: For more details on Dell Service Plans please to go to www.dell.com/service/service_plans/

	DT	SFF
3 Year Warranty ⁶ Next Business Day On-site ⁷ Service (3-3-3)	Standard	
Dell ProSupport	Optional	

⁶ For a copy of our guarantees or limited warranties, please write Dell USA L.P., Attn: Warranties, One Dell Way, Round Rock, TX 78682. For more information, visit www.dell.com/warranty.

⁷ Service may be provided by third-party. Technician will be dispatched if necessary following phone-based troubleshooting. Subject to parts availability, geographical restrictions and terms of service contract. Service timing dependent upon time of day call placed to Dell. U.S. only.

Software

	DT	SFF
Dell Client Manager	Available via Dell.com	
Dell Control Point	Standard	
Dell Backup & Recovery Manager	Optional	
Norton Internet Security 2010	30 Day Trial or Optional Subscription	
McAfee 10 Security Center	30 Day Trial or Optional Subscription	
Trend Micro Internet Security	30 Day Trial or Optional Subscription	

Chassis Accessories

NOTE: For more details on chassis accessory installation and maintenance, please to go:

<http://support.dell.com/support/edocs/systems/opXE/>

	DT	SFF
Cooling / Ventilation Accessories		
Up to 131F / 55C Temperature Ducting Kit	Optional	
Dust Protection		
Dust Filter	Optional	
Ingress Protection (IP) level 51 Kit	Optional	
System Mounting/Enclosure Options		
System Mounting Bracket	Optional	
Routing for External Power Switch	Optional	
Dell Cable Cover		Optional

Detailed Engineering Specifications

System Dimensions (Physical)

NOTE: System Weight and Shipping Weight is based on a typical configuration and may vary based on PC configuration. A typical configuration includes: Integrated graphics, one hard drive, and one optical drive

	DT	SFF
Chassis Volume (liters)	15L	8L
Chassis Weight (pounds/kilograms)	20.6lbs. / 9.38kg	14.3lbs. / 6.48kg
Chassis Dimensions: (HxWxD)		
Height (inches/centimeters)	4.3in. / 10.91cm	3.35in. / 8.52cm
Width (inches/centimeters)	15.61in. / 39.65cm	11.4in. / 28.96cm
Depth (inches/centimeters)	13.75in. / 34.91cm	12.74in. / 32.36cm
Shipping Weight⁸ (pounds/kilograms - includes packaging materials)	27.0lbs. / 12.25kg	20.0lbs. / 9.07kg
Packaging Parameters (HxWxD)		
Height (inches/centimeters)	20.35in. / 517cm – 20.63in. / 524cm	20.75in. / 527cm – 20.88in. / 530cm
Width (inches/centimeters)	20.04in. / 509cm – 20.31in. / 516cm	16.38in. / 416cm – 19.38in. / 492cm
Depth (inches/centimeters)	11.96in. / 304cm – 11.88in. / 302cm	11.25in. / 286cm – 10.63in. / 270cm

⁸ Shipping weights may vary slightly by region

System Board Connector Maximum Allowable Dimensions

	DT	SFF
PCI Slot(s) Dimensions: (HxL)	2	1
Height (inches/centimeters)	2.13in. / 5.4cm	
Length (inches/centimeters)	6.57in. / 16.7cm	
PCIe x16 Slot Dimensions: (HxL)	1	1
Height inches/centimeters	2.13in. / 5.4cm	
Length inches/centimeters	6.57in. / 16.7cm	
PCIe x1 Slot Dimensions: (HxL)	1	
Height inches/centimeters	2.13in. / 5.4cm	
Length inches/centimeters	6.57in. / 16.7cm	
Risers: (replaces 1 PCI slot and PCIe x16 slot on DT system board)		
Combo Full Height Riser with 1 PCI and 1 PCIe x16 connector (HxL)	1	
Height inches/centimeters	3.78in. / 9.6cm	
Length inches/centimeters ^{9,10}	6.89in. / 17.5cm	
Dual Full Height Riser with 2 PCI connectors (HxL)	1	
Height inches/centimeters	3.78in. / 9.6cm	
Length inches/centimeters ^{9,10}	6.89in. / 17.5cm	

⁹ Card length can be longer than standard Half-Length Card but cannot be a Full-Length Card

¹⁰ 6.9in. / 17.53cm is longer than the standard Half-Length Card

System Level Environmental and Operating Conditions

	DT	SFF
Temperature¹¹		
Operating	10° to 45°C (50° to 113°F)	
Non-Operating (Storage)	-40° to 60°C (-40° to 140°F)	
Relative Humidity		
20% to 80% (non-condensing)		
Maximum Vibration		
Operating	Random Vibe 5~500Hz, 0.26Grms, 2 sides	
Non-Operating	Random Vibe 5~500Hz, 2.2Grms, 6 sides	
Maximum Shock		
Operating	HALF SN 40G/2ms, 2 sides	
Non-Operating	HALF SN 105G/2ms, 6 sides	
Maximum Altitude		
Operating	-15.2 to 3048 m (-50 to 10,000 ft)	
Non-Operating	-15.2 to 10,668 m (-50 to 35,000 ft)	

¹¹The OptiPlex XE is tested to withstand 24x7 operation in 45°C environments standard within 3 year warranty period, and can support 24x7 operation over 3 year warranty period in environments up to 55°C with use of optional ducting kit. The XE motherboard uses at least 105°C/3000 hrs E-Capacitors or Polymer Capacitors. The XE motherboard also uses at least 15u gold plating for internal connectors/slots and normal 30u gold plating for external ports (except for VGA/10u and Serial/15u). Overcurrent protection polyfuses are used on USB, serial, PS/2, VGA and DP ports, and thermal sensors on CPU, SIO chip, CPU inlet, and PSU inlet for thermal protection.

Power

NOTE: The OptiPlex XE utilizes wide-ranging power supplies. These power supplies do not require users to switch or reconfigure the PSU when alternating between 100-240VAC electrical currents/sockets. The XE also uses a more efficient Active Power Factor Correction (APFC) power supply. Dell recommends only Uninterruptible Power Supplies (UPS) based on Sine Wave output for APFC PSUs, not an approximation of a Sine Wave, Square Wave, or quasi-Square Wave. If you have questions, please contact the manufacture to confirm the output type.

	DT (EPA)	SFF (EPA)
Power Supply Wattage	300W High Efficiency	280W High Efficiency
AC input Voltage Range	100 to 240Vac	100 to 240Vac
AC input current (low ac range/high AC range)	6.0A / 3.0A	5.0A / 2.5A
AC input Frequency	50HZ / 60HZ	50HZ / 60HZ
AC holdup time (80% load)	16MSEC	16MSEC
Average Efficiency (Energy Star 5.0 Compliant)	88%	88%
DC parameters		
+3.3v output	6.0A	6.0A
+5.0v output	16A	16A
+12.0v output	18A	17A
+5.0v auxiliary output	4.0A	4.0A
-12.0v output	0.5A // 24.8Vdc/3.0A	0.5A // 24.8Vdc/3.0A
Max total power	300W	280W
Max combined +3.3v / +5.0v power	90watt	90watt
Max combined 12.0v power (note: only if more than one 12v rail)	NA—only one 12V rail	NA—only one 12V rail
BTUs/h (based on PSU max wattage)	1163	1085
3.3v CMOS battery (type and estimated battery life)		
Power Supply Fan	92*25mm	80*15mm
Compliance:		
1watt requirement	Yes	Yes
Blue Angel Compliant	No	No
Climate Savers / 80Plus Compliant	Yes	Yes
FEMP (CECP) Standby Power Compliant	Yes	Yes
EnergyStar5.0	Yes (select configurations)	Yes (select configurations)
EPEAT Gold	Yes (select configurations)	Yes (select configurations)
EuP	Yes	Yes
TCO 05	Yes	Yes
WEEE	Yes	Yes
Japan Energy Law	Yes	Yes
CEC	Yes	Yes
Japan Green PC	Yes	Yes
FEMP	Yes	Yes
South Korea Eco-Label	Yes	Yes
EU RoHS	Yes	Yes
China RoHS	Yes	Yes

Audio

INTEGRATED RELTECK ALC269 –VB3 HIGH DEFINITION AUDIO

	DT	SFF
High Definition Stereo support	X	X
Number of channels	2	
Number of Bits / Audio resolution	16, 20, and 24-bit resolution	
Sampling rate (recording/playback)	Independent 8, 11.025, 16, 22.05, 32, 44.1, 48, 88.2, 96, 176.4, and 192 kHz sample rates	
Signal to Noise Ratio	96+ dB audio outputs, 90+ dB audio inputs	
Analog Audio	X	X
Dolby Digital		
THX		
Digital out (S/PDIF)		
Audio Jack Impedance		
Microphone	50 k Ω	
Line-In	50 k Ω	
Line-Out	100 Ω	
Headphone	2 Ω	
Internal Speaker Power Rating	1W/8 Ohm	

Communications – Primary Integrated LAN

NOTE: The OptiPlex XE supports 2 on-board LOMs (LAN On Motherboard) standard

INTEGRATED BROADCOM® BCM5761 NETXTREME® 10/100/1000 GIGABIT ETHERNET (GBE)	DT	SFF
External Connector Type	RJ45	
Data Rates supported	10/100/1000 Mbps	
Controller Details		
Controller bus architecture	PCIe 1.1 x1	
Integrated memory	48-KB rx and 8-KB tx buffer	
Data transfer mode (example Bus-Master DMA)	DMA	
Power consumption (full operation per data rate connection speed)	1023mW (+5% for 1.2V and 2.5V, nominal +10% for 3.3VMax.)	
Power consumption (standby operation)	203mW (D3cold with WOL enabled.)	
IEEE standards compliance (example 802.1P)	802.3	
Hardware Certifications (example FCC, B, GS mark...)	RoHS	
Boot ROM Support	SPI flash	
Network Transfer Mode (example Full Duplex, Half Duplex)		
Network Transfer Rate (example 10BASE-T (half-duplex) 10 Mbps 10BASE-T (full-duplex) 20 Mbps 100BASE-TX (half-duplex) 100 Mbps 100BASE-TX (full-duplex) 200 Mbps 1000BASE-T (full-duplex) 2000 Mbps)	10 Mb (full/half-duplex) 100 Mb (full/half-duplex) 1000 Mb (full-duplex)	
Environmental		
Operating temperature	0° C to 70° C (32° F to 158° F)	
Operating humidity	20% to 80% (non-condensing)	
Operating System Driver Support	Windows® XP, Windows Vista® Ultimate, Windows Vista® Business 32 bit/64 bit, Windows Vista Home Basic	
Manageability (examples WOL, PXE)	WOL, PXE 2.1	
Management Capabilities Alerting	Broadcom® TruManage™	

Communications – Secondary Integrated LAN

BROADCOM® BCM57780 NETLINK® 10/100/1000 GIGABIT ETHERNET (GBE)

	DT	SFF
Connector Type	RJ45	
Data Rates supported	10/100/1000 Mbps Half/Full duplex	
Controller Details		
Controller bus architecture (example PCIe 1.0a x1)	PCIe 1.1 x1	
Integrated memory	16KBytes RX, 8KBytes TX	
Data transfer mode (example Bus-Master DMA)	DMA	
Power consumption (full operation per data rate connection speed)	804mW(+5% for 1.2V, nominal +10% for 3.3VMax.)	
Power consumption (standby operation)	73mW(10Base-T,WOL enabled)	
IEEE standards compliance (example 802.1P)	802.3, 802.3u,80.3ab, 802.3z, 802.1p	
Hardware Certifications (example FCC, B, GS mark...)	RoHS	
Boot ROM Support	No	
Network Transfer Mode (example Full Duplex, Half Duplex)	Full Duplex/Half Duplex	
Network Transfer Rate (example 10BASE-T (half-duplex) 10 Mbps 10BASE-T (full-duplex) 20 Mbps 100BASE-TX (half-duplex) 100 Mbps 100BASE-TX (full-duplex) 200 Mbps 1000BASE-T (full-duplex) 2000 Mbps)	10BASE-T (full-duplex) 20 Mbps Max* 100BASE-TX (half-duplex) 100 Mbps Max* 100BASE-TX (full-duplex) 200 MbpsMax* 1000BASE-T (full-duplex) 2000 Mbps Max* * Depends on the system environment.	
Environmental		
Operating temperature	0° C to 70° C (32° F to 158° F)	
Operating humidity	5% ~ 85% (non-condensing)	
Operating System Driver Support	Windows® 7, Windows® XP, Windows Vista® Ultimate, Windows Vista® Business 32 bit/64 bit, Windows Vista Home Basic, Linux	
Manageability (examples WOL, PXE)	WOL, PXE2.1, ACPI	
Management Capabilities Alerting	None	

Communications – Wireless

DELL WIRELESS 1520 PCIE WLAN CARD (802.11N WITH REMOTE WAKE UP SUPPORT)	DT	SFF
External Connector Type	Custom WLAN Antenna Connector	
Controller Details		
Controller bus architecture	PCIe 1.0a x1	
WLAN standards supported	802.11a, 802.11b, 802.11g, 802.11n	
802.11b Data Rates supported	11, 5.5, 2, 1 Mbps	
802.11a Data Rates supported	54, 48, 36, 24, 18, 12, 9, 6 Mbps	
802.11g Data Rates supported	54, 48, 36, 24, 18, 12, 9, 6 Mbps	
802.11n Data Rates supported	450, 300, 270, 243, 240, 180, 150, 144, 135, 130, 120, 117, 115.5, 90, 86.667, 72.2, 65, 60, 57.8, 45, 43.3, 30, 28.9, 21.7, 15, 14.4, 7.2 Mbps	
Encryption	WEP 64-bit and 128-bit, TKIP, AES-CCMP 128-bit	
Operating temperature	0 - 80°C	
Operating humidity	50% to 95% non-condensing (at temperatures of 25 °C to 35 °C)	
Operating System Driver Support	Windows 7, Windows XP 32, Vista 32/64	

Graphics/Video Controller

NOTE: DT supports low profile card or full height card with optional riser. SFF supports low profile card.

INTEGRATED INTEL GMA 4500 ^{12, 13}	DT	SFF
Bus Type	Integrated	
GPU core clock	Gen5 core @ 667 350 MHz Integrated and with 350MHz 24 bit RAMDAC	
Frame Buffer Memory (onboard and shared) Size and Speed	XP: Up to 512MB with 1GB system memory; up to 1GB with 2GB system memory Vista and Win7: Up to 272MB with 1GB system memory; up to 784MB with 2GB system memory; up to 1296MB with 3GB system memory; up to 1808MB with 4GB system memory; up to 3856MB with 8GB system memory	
Maximum power consumption	4 W	
Overlay Planes	Yes	

Maximum Color Depth	32 bit
Maximum Vertical Refresh Rate	85 Hz
Multiple Display Support	Yes
Operating Systems Graphics/ Video API Support	OpenGL 2.0/DirectX 10.0
Supported Resolutions and Max Refresh Rates (Hz) (Note: Analog and/or digital)	Up to 2560x1600 @ 60Hz (DP) Up to 1920x1200 @ 60Hz (DVI & VGA) Up to 1600x1200 @ 85Hz (VGA only)
External Connectors	VGA, DisplayPort
Environmental Operating Conditions (Non-Condensing):	
Operating Temperature Range	0° to 106° C (32° to 223° F)
Relative Humidity Range	20% to 80% (non-condensing)
Altitude Range	-15.2 to 3048 m (-50 to 10,000 ft)
DisplayPort	
Bus Type	AUX 1, 2, 4 lanes
Maximum supported resolution	Up to 2560x1600 @ 60Hz
Maximum power consumption	N/A
External connectors	DisplayPort
DVI (Digital) Add Card	
Bus Type	sDVO
Maximum supported resolution	Up to 1920x1566 @ 60 Hz
Dimensions of full height card inches/centimeters (L x H)	5.75 x 2.75 / 14.61 x 6.99
Dimensions of low profile card inches/centimeters (L x H)	5.75 x 2.75 / 14.61 x 6.99
Maximum power consumption	N/A
External connectors	DVI

¹² DVI and VGA can be used concurrently for multi-monitor display in DOS. The DisplayPort controller does not support multi-monitor display in DOS

¹³ Populating a discrete graphics card in the x16 slot disables onboard video.

512MB AMD RADEON™ HD 4550 GRAPHICS, DP + DVI¹⁴

	DT	SFF
Bus Type (example integrated or PCIe x16)	PCIEx16	
GPU core clock	750Mhz	
Frame Buffer Memory (onboard and shared) Size and Speed	800Mhz	
Maximum power consumption	25W	
Overlay Planes	Yes	
Maximum Color Depth	32-bit	

512MB AMD RADEON™ HD 4550 GRAPHICS, DP + DVI¹⁴

	DT	SFF
Maximum Vertical Refresh Rate	85Hz	
Multiple Display Support	Yes	
Operating Systems Graphics/ Video API Support	D3D and OpenGL	
Supported Resolutions and Max Refresh Rates (Hz) (Note: Analog and/or digital)	Max : 1920x1440/32bpp @ 75Hz Min : 640x480/8bpp @ 60Hz	
External connectors¹⁵	Display Port, DVI	
Dimensions of full height card inches/centimeters (L x H)	167.64mm x 120mm	
Dimensions of low profile card inches/centimeters (L x H)	167.64mm x 85mm	
Environmental Operating Conditions (Non-Condensing):		
Operating Temperature Range	10°-50° C	
Relative Humidity Range	5-90% RH	
Altitude Range	0-20,000 ft.	

¹⁴ Systems using the 512MB AMD Radeon™ HD 4550 graphics card will have a maximum operating temperature of 35°C (95°F)

¹⁵ Dongles Supported: DP-VGA (RN699), DP-DVI (23NVR), DP-DL DVI (XT625), DP-HDMI(TK041)

Hard Drives

3.5" 160GB SATA 7200 RPM HDD

Capacity (bytes)	160,041,885,696
Dimensions inches (W x D x H)	5.87 x 4 x 1
Interface type and Maximum speed	Up to 3Gb/s
Internal buffer size	8 MB
Average Seek Time	8.5 ms
Rotational Speed	7200 rpm
Logical Blocks	312,581,808
Power Source	
DC Power (Max)	Idle 7.0W, Active 10.0W
DC Current	5V (.8A) and 12V (1.8A)
Environmental Operating Conditions (Non-Condensing):	
Temperature Range	5°C to 60°C
Relative Humidity Range	20% to 80% non-condensing
Maximum Wet Bulb Temperature	29°C
Altitude Range	-50 ft to 10000 ft

3.5" 160GB SATA 7200 RPM HDD (CONT.)

Environmental Non-Operating Conditions (Non-Condensing):	
Temperature Range	-40 ⁰ C to 65 ⁰ C
Relative Humidity Range	10% to 90% non-condensing
Maximum Wet Bulb Temperature	38 ⁰ C
Altitude Range	-50 ft to 35000 ft

3.5" 250GB SATA 7200 RPM HDD

Capacity (bytes)	250,059,350,016
Dimensions inches (W x D x H)	5.87 x 4 x 1
Interface type and Maximum speed	Up to 3Gb/s
Internal buffer size	8 MB
Average Seek Time	8.5 ms
Rotational Speed	7200 rpm
Logical Blocks	488,397,168
Power Source	
DC Power (Max)	Idle 7.0W, Active 10.0W
DC Current	5V (.8A) and 12V (1.8A)
Environmental Operating Conditions (Non-Condensing):	
Temperature Range	5 ⁰ C to 60 ⁰ C
Relative Humidity Range	20% to 80% non-condensing
Maximum Wet Bulb Temperature	29 ⁰ C
Altitude Range	-50 ft to 10000 ft
Environmental Non-Operating Conditions (Non-Condensing):	
Temperature Range	-40 ⁰ C to 65 ⁰ C
Relative Humidity Range	10% to 90% non-condensing
Maximum Wet Bulb Temperature	38 ⁰ C
Altitude Range	-50 ft to 35000 ft

3.5" 320GB SATA 7200 RPM HDD

Capacity (bytes)	320,072,933,376
Dimensions inches (W x D x H)	5.87 x 4 x 1
Interface type and Maximum speed	Up to 3Gb/s
Internal buffer size	16 MB
Average Seek Time	8.5 ms
Rotational Speed	7200 rpm
Logical Blocks	625,142,448
Power Source	
DC Power (Max)	Idle 7.0W, Active 10.0W
DC Current	5V (.8A) and 12V (1.8A)
Environmental Operating Conditions (Non-Condensing):	
Temperature Range	5 ⁰ C to 60 ⁰ C
Relative Humidity Range	20% to 80% non-condensing
Maximum Wet Bulb Temperature	29 ⁰ C
Altitude Range	-50 ft to 10000 ft
Environmental Non-Operating Conditions (Non-Condensing):	
Temperature Range	-40 ⁰ C to 65 ⁰ C
Relative Humidity Range	10% to 90% non-condensing
Maximum Wet Bulb Temperature	38 ⁰ C
Altitude Range	-50 ft to 35000 ft

3.5" 500GB SATA 7200 RPM HDD

Capacity (bytes)	500,107,862,016
Dimensions inches (W x D x H)	5.87 x 4 x 1
Interface type and Maximum speed	Up to 3Gb/s
Internal buffer size	16 MB
Average Seek Time	8.5 ms
Rotational Speed	7200 rpm
Logical Blocks	976,773,168
Power Source	
DC Power (Max)	Idle 7.0W, Active 10.0W
DC Current	5V (.8A) and 12V (1.8A)

Environmental Operating Conditions (Non-Condensing):	
Temperature Range	5 ^o C to 60 ^o C
Relative Humidity Range	20% to 80% non-condensing
Maximum Wet Bulb Temperature	29 ^o C
Altitude Range	-50 ft to 10000 ft
Environmental Non-Operating Conditions (Non-Condensing):	
Temperature Range	-40 ^o C to 65 ^o C
Relative Humidity Range	10% to 90% non-condensing
Maximum Wet Bulb Temperature	38 ^o C
Altitude Range	-50 ft to 35000 ft

2.5" 160GB SATA 7200 RPM HDD

Capacity (bytes)	160,144,285,696
Dimensions inches (W x D x H)	Approximately (3.93 x 2.75 x 0.374 inches)
Interface type and Maximum speed	Up to 3Gb/s
Internal buffer size	16 MB
Average Seek Time	12 ms (Read)
Rotational Speed	7200 rpm
Logical Blocks	312,581,808
Power Source	
DC Power (Max)	Idle 1.0W, Active 3.25W
DC Current	5V (.8A)
Environmental Operating Conditions (Non-Condensing):	
Temperature Range	5 ^o C to 60 ^o C
Relative Humidity Range	10% to 90% non-condensing
Maximum Wet Bulb Temperature	29 ^o C
Altitude Range	-50 ft to 10000 ft
Environmental Non-Operating Conditions (Non-Condensing):	
Temperature Range	-40 ^o C to 65 ^o C
Relative Humidity Range	10% to 90% non-condensing
Maximum Wet Bulb Temperature	38 ^o C
Altitude Range	-50 ft to 35000 ft

2.5" 250GB SATA 7200 RPM HDD

Capacity (bytes)	
Dimensions inches (W x D x H)	Approximately (3.93 x 2.75 x 0.374 inches)
Interface type and Maximum speed	Up to 3Gb/s
Internal buffer size	16 MB
Average Seek Time	12 ms (Read)
Rotational Speed	7200 rpm
Logical Blocks	488,397,168
Power Source	
DC Power (Max)	Idle 1.0W, Active 3.25W
DC Current	5V (.8A)
Environmental Operating Conditions (Non-Condensing):	
Temperature Range	5 ⁰ C to 60 ⁰ C
Relative Humidity Range	10% to 90% non-condensing
Maximum Wet Bulb Temperature	29 ⁰ C
Altitude Range	-50 ft to 10000 ft
Environmental Non-Operating Conditions (Non-Condensing):	
Temperature Range	-40 ⁰ C to 65 ⁰ C
Relative Humidity Range	10% to 90% non-condensing
Maximum Wet Bulb Temperature	38 ⁰ C
Altitude Range	-50 ft to 35000 ft

2.5" 250GB SATA Full Disk Encryption HDD

Capacity (bytes)	250,059,350,016
Dimensions inches (W x D x H)	Approximately (3.93 x 2.75 x 0.374 inches)
Interface type and Maximum speed	Up to 3Gb/s
Internal buffer size	16 MB
Average Seek Time	12 ms (Read)
Rotational Speed	7200 rpm
Logical Blocks	488,397,168
Power Source	
DC Power (Max)	Idle 1.0W, Active 3.25W
DC Current	5V (.8A)

Environmental Operating Conditions (Non-Condensing):	
Temperature Range	5 ^o C to 60 ^o C
Relative Humidity Range	10% to 90% non-condensing
Maximum Wet Bulb Temperature	29 ^o C
Altitude Range	-50 ft to 10000 ft
Environmental Non-Operating Conditions (Non-Condensing):	
Temperature Range	-40 ^o C to 65 ^o C
Relative Humidity Range	10% to 90% non-condensing
Maximum Wet Bulb Temperature	38 ^o C
Altitude Range	-50 ft to 35000 ft

2.5" 64GB SATA SOLID STATE DRIVE

Capacity (bytes)	64,023,257,088
Dimensions inches (W x D x H)	3.94 x 2.75 x 0.374
Interface type and Maximum speed	Up to 3Gb/s
MTBF	1M hours
Average Seek Time	n/a
Performance: Sequential Read/ Write	220/200 (MB/s)
Performance: SYSmark '07 Overall Score	156
Logical Blocks	125,045,424
Power Source	
DC Power Consumption (Max)	Idle 0.205W, Active 0.435W
DC Current	5V (0.8A)
Environmental Operating Conditions (Non-Condensing):	
Temperature Range	0 ^o C to 70 ^o C
Relative Humidity Range	10 to 90%
Maximum Wet Bulb Temperature	29 ^o C
Altitude Range	-200 to 5,000 m
Op Shock (@0.5ms)	1,500G
Environmental Non-Operating Conditions (Non-Condensing):	
Temperature Range	-55 ^o C to 95 ^o C
Relative Humidity Range	5 to 95%
Maximum Wet Bulb Temperature	38 ^o C
Altitude Range	-200 to 10,600 m

2.5" 128GB SATA SOLID STATE DRIVE

Capacity (bytes)	128,035,676,160
Dimensions inches (W x D x H)	3.94 x 2.75 x 0.374
Interface type and Maximum speed	Up to 3Gb/s
MTBF	1M hours
Average Seek Time	n/a
Performance: Sequential Read/ Write	Up to 220/200 (MB/s)
Performance: SYSmark '07 Overall Score	TBD
Logical Blocks	250,069,680
Power Source	
DC Power Consumption (Max)	Idle 0.205W, Active 0.435W
DC Current	5V (0.8A)
Environmental Operating Conditions (Non-Condensing):	
Temperature Range	0°C to 70°C
Relative Humidity Range	10 to 90%
Maximum Wet Bulb Temperature	29°C
Altitude Range	-200 to 5,000 m
Op Shock (@0.5ms)	1,500G
Environmental Non-Operating Conditions (Non-Condensing):	
Temperature Range	-55°C to 95°C
Relative Humidity Range	5 to 95%
Maximum Wet Bulb Temperature	38°C
Altitude Range	-200 to 10,600 m

Optical Drives

DVD +/- RW ¹⁶	DT	SFF
External Dimensions inches/centimeters (Without Bezel – W x H x D)	148.2mm(6in)/42mm (2in)/ 190.5 (max)	128.0 mm (5.04)/ 12.7mm (0.5 in)/ 126.1mm (4.97in)
Weight (max) pounds/kilograms	800g	170g
Interface type and speed	SATA 1.5Gbit/s	SATA 1.5Gbit/s
Disc Capacity	Standard	Standard
Internal buffer size	supplier dependent	supplier dependent
Access Times (typical)	supplier dependent	supplier dependent
Maximum Data Transfer Rates		
Writes	16x DVD/48x CD	8x DVD/ 24x CD
Reads	16x DVD/48x CD	8x DVD/ 24x CD
Power Source		
DC Power Requirements	12V, 5V	5V
DC Current	1200mA (12V)/ 900mA (5V)	1000mA
Environmental Operating Conditions (Non-Condensing):		
Operating Temperature Range	5C to 50C	5C to 50C
Relative Humidity Range	20% to 80% RH	20% to 80% RH
Maximum Wet Bulb Temperature	29C	29C
Altitude Range	-200 to 3048	-200 to 3048
Environmental Non-Operating Conditions (Non-Condensing):		
Operating Temperature Range	-40C to 65C	-40C to 65C
Relative Humidity Range	5% to 95% RH	5% to 95% RH
Maximum Wet Bulb Temperature	38C	38C
Altitude Range	-200 to 10600m	-200 to 10600m

¹⁶ Discs burned with this drive may not be compatible with some existing drives and players; using DVD+R media provides maximum compatibility.

DVD-ROM	DT	SFF
External Dimensions inches/centimeters (Without Bezel – W x H x D)	148.2mm(6in)/42mm (2in)/ 190.5 (max)	128.0 mm (5.04)/ 12.7mm (0.5 in)/ 126.1mm (4.97in)
Weight (max) pounds/kilograms	750g	165g
Interface type and speed	SATA 1.5Gbit/s	SATA 1.5Gbit/s
Disc Capacity	Standard	Standard
Internal buffer size	supplier dependent	supplier dependent
Access Times (typical)	supplier dependent	supplier dependent

Maximum Data Transfer Rates		
Writes	N/A	N/A
Reads	16x DVD/48x CD	8x DVD/ 24x CD
Power Source		
DC Power Requirements	12V, 5V	5V
DC Current	1200mA (12V)/ 900mA (5V)	800mA
Environmental Operating Conditions (Non-Condensing):		
Operating Temperature Range	5C to 50C	5C to 50C
Relative Humidity Range	20% to 80% RH	20% to 80% RH
Maximum Wet Bulb Temperature	29C	29C
Altitude Range	-200 to 3048m	-200 to 3048m
Environmental Non-Operating Conditions (Non-Condensing):		
Operating Temperature Range	-40C to 65C	-40C to 65C
Relative Humidity Range	5% to 95% RH	5% to 95% RH
Maximum Wet Bulb Temperature	38C	38C
Altitude Range	-200 to 10600m	-200 to 10600m

BIOS Defaults

Drives	Diskette drive:	USB
	SATA Operation:	RAID On
	SMART Reporting:	Disable
	SATA-0:	Enable
	SATA-1:	Enable
System Configuration	Integrated NIC:	Enable
	USB Controller:	Enable
	Serial Port #1:	Auto
	Serial Port #2:	Auto
	Front USB:	Enable
	Rear Dual USB (Under NIC1) and Powered USB:	Enable
	Rear Dual USB (Under NIC2):	Enable
	PCI Slots:	Enable
	WIFI NIC Slot:	Enable
Audio:	Enable	
Video	Primary Video:	Auto

Performance	Multiple CPU Core:	Enable
	Intel® SpeedStep™:	Disable, unless the customer purchased a SpeedStep™ capable processor.
	C States Control:	Enable
	Limit CPUID Value:	Disable
Virtualization Support	Virtualization:	Enable
	VT for Direct I/O:	Disable
Security	Administrator Password:	Not set
	System Password:	Not set
	Password Changes:	Enable
	CPU XD Support:	Enable
	Computrace®:	Deactivate
	SATA-0 Password:	Not set
Power Management	AC Recovery:	Power Off
	Auto On Time:	Disable
	Low Power Mode:	Enable
	Remote Wake Up:	Disable
	Suspend Mode:	S3
	Fan Control Override:	Disable
Maintenance	Service Tag:	Set by the factory
	Asset Tag:	Optional User Entry
	SERR Message:	Enable
	Systems Management	Disable
Post Behavior	Fast Boot:	Enable
	Numlock LED:	Enable
	POST HotKeys:	Enable
	Keyboard Errors:	Enable

Chassis Enclosure & Ventilation Requirements

Enclosure Ventilation

If your enclosure has doors, they need to be of a type that allows at least 30% airflow through the enclosure (front and back).

Enclosure Minimum Clearance

Leave a 10.2 cm (4 in.) minimum clearance on all vented sides of the computer to permit the airflow required for proper ventilation.

Recommended Enclosure

Do not install your computer in an enclosure that does not allow airflow. This restricts the airflow and impacts your computer's performance, possibly causing it to overheat.

Open Desk Minimum Clearance

If your computer is installed in a corner, on a desk, or under a desk, leave at least 5.1 cm (2 in.) clearance from the back of the computer to the wall to permit the airflow required for proper ventilation.

Regulatory Compliance and Environmental

Product related conformity assessment and regulatory authorizations including Product Safety, Electromagnetic Compatibility (EMC), Ergonomics, Communication Devices relevant to this product, along with additional product related conformity assessment, and information encompassing Environmental, Energy Consumption, Noise Emissions, Product Materials Information, Packaging, Batteries, and Recycling relevant to this product may be viewed in the Regulatory and Environmental Datasheet for this product is located at: http://www.dell.com/content/topics/global.aspx/about_dell/values/regulatory_compliance/dec_conform?c=us&l=en&s=corp&~ck=anavml

Details of Dell's environmental stewardship program to conserve product energy consumption, reduce or eliminate materials for disposal, prolong product life span and provide effective and convenient equipment recovery solutions may be viewed at www.dell.com/earth by clicking the Design for Environment link on the webpage.



Acoustic Noise Emission Information

OptiPlex XE DT

Component	Typical Configuration	High-end Configuration
CPU	Intel® Pentium® Dual-Core E5300	Intel® Core™ 2 Duo E7400
Memory	2GB DDR3 1066 MHz (x1)	2GB DDR3 1066 MHz (x4)
HDD (#, capacity)	160GB 7200 RPM SATA2	500GB 7200 RPM SATA2 (x2)
RMSD	DVDRW/DVD dual config	DVDRW/DVD dual config
Graphics Adapter	Integrated Intel GMA 4500	Integrated Intel GMA 4500

The Declared Noise Emission in accordance with ISO 9296 for the Dell OptiPlex XE DT is as follows (all values L_{WAd} expressed in bels; 1 bel=10 decibels, re 10^{-12} Watts):

Operating Mode	Typical Configuration Declared Sound Power (L_{WAd})	High-end Configuration Declared Sound Power (L_{WAd})
Idle	3.76	3.81
HDD Operating	3.68	3.84
90% CPU	3.96	3.85
ODD Operating	5.16	5.19

The Declared A-weighted Sound Pressure Level in decibels (re 2×10^{-5} Pa), at Operator, Bystander, and Desk Side Positions are measured in accordance with ISO 7779 7.6.1, 7.6.2, and C.15.2 and declared in accordance with ISO 9296 for this product is as follows^{17, 18}:

Operating Mode	Typical Configuration Declared Sound Pressure (LpA)				High-end Configuration Declared Sound Pressure (LpA)			
	Table-Top		Floor-Standing		Table-Top		Floor- Standing	
	Operator Position (LpA)	Bystander Position (LpA)	Operator Position (LpA)	Bystander Position (LpA)	Operator Position (LpA)	Bystander Position (LpA)	Operator Position (LpA)	Bystander Position (LpA)
Idle	25.00	21.50	21.00	20.30	25.48	22.00	21.43	20.90
HDD Operating	25.00	21.80	21.07	20.06	25.40	22.00	21.50	21.10
90% CPU	25.37	22.00	21.04	21.80	26.72	23.40	22.39	22.50
ODD Operating	43.06	37.40	35.18	34.00	43.80	37.83	34.84	34.10

¹⁷ All tests are conducted according to ISO 7779 and declared according to ISO 9296 except 90% CPU. For this mode, the system CPU was stressed at 90% utilization with no other peripheral device actively seeking. This test mode is not specified in ISO 7779, but was measured using the same microphone distances and measurement techniques defined for the other reported operating modes.

¹⁸ Declared Sound Power rounded to nearest tenth of a bel per ISO 9296 section 4.4.2

OptiPlex XE SFF

Component	Typical Configuration	High-end Configuration
CPU	Intel® Pentium® Dual-Core E5300	Intel® Core™ 2 Duo E7400
Memory	2GB DDR3 1066 MHz (x1)	2GB DDR3 1066 MHz (x4)
HDD (#, capacity)	160GB 7200 RPM SATA2	250GB 7200 RPM SATA2 (x2)
RMSD	DVDRW/DVD dual config	DVDRW/DVD dual config
Graphics Adapter	Integrated Intel GMA 4500	Integrated Intel GMA 4500

The Declared Noise Emission in accordance with ISO 9296 for the Dell OptiPlex XE SFF is as follows (all values L_{WAd} expressed in bels; 1 bel=10 decibels, re 10^{-12} Watts):

Operating Mode	Typical Configuration Declared Sound Power (L_{WAd})	High-end Configuration Declared Sound Power (L_{WAd})
Idle	3.27	3.15
HDD Operating	3.26	3.24
90% CPU	3.66	3.88
ODD Operating	4.51	4.79

The Declared A-weighted Sound Pressure Level in decibels (re 2×10^{-5} Pa), at Operator, Bystander, and Desk Side Positions are measured in accordance with ISO 7779 7.6.1, 7.6.2, and C.15.2 and declared in accordance with ISO 9296 for this product is as follows^{17, 18}:

Operating Mode	Typical Configuration Declared Sound Pressure (LpA)				High-end Configuration Declared Sound Pressure (LpA)			
	Table-Top		Floor-Standing		Table-Top		Floor- Standing	
	Operator Position (LpA)	Bystander Position (LpA)	Operator Position (LpA)	Bystander Position (LpA)	Operator Position (LpA)	Bystander Position (LpA)	Operator Position (LpA)	Bystander Position (LpA)
Idle	24.05	21.10	20.53	19.30	23.74	21.40	19.80	18.60
HDD Operating	23.85	21.10	20.77	19.40	23.89	21.40	20.50	19.00
90% CPU	25.26	21.70	20.91	20.40	29.24	24.90	23.93	21.40
ODD Operating	38.50	33.40	29.06	28.10	38.82	33.50	30.59	28.50

¹⁷ All tests are conducted according to ISO 7779 and declared according to ISO 9296 except 90% CPU. For this mode, the system CPU was stressed at 90% utilization with no other peripheral device actively seeking. This test mode is not specified in ISO 7779, but was measured using the same microphone distances and measurement techniques defined for the other reported operating modes.

¹⁸ Declared Sound Power rounded to nearest tenth of a bel per ISO 9296 section 4.4.2