



Data Center Bridging: enabling enterprise-class, multipurpose Ethernet

Ethernet's predominance in the data center owes to numerous advantages, including its standard specification, inherent scalability, and its consequent broad market adoption, accessibility and cost-effectiveness. As a data center networking fabric, however, Ethernet has a critical flaw: its nondeterministic design. Because Ethernet was designed to be susceptible to dropped packets and delay due to congestion, many data centers incorporate multiple, discrete networks (often comprising a mix of Ethernet and Fibre Channel or Infiniband), each dedicated to a specific function and protected from unwanted resource contention.

Growing numbers of data centers have transitioned from Gigabit Ethernet (GbE) to 10GbE, driven by bandwidth-thirsty applications, denser server architectures, and declining 10GbE switching costs. Data center managers have even begun to explore the potential of 40GbE and 100GbE data center networks. Given this fast-paced evolution, organizations face new pressure to fully leverage their capital investments and minimize their operating costs. The ability to consolidate all data center traffic onto a single, high-capacity Ethernet fabric is therefore critical.

Data Center Bridging (DCB) defines a set of Ethernet specifications intended to address this requirement. To accommodate the migration of an expanding list of traffic types to 10GbE, data center architects need the ability to classify and prioritize different data flows. DCB accomplishes this, reducing the number of failure points in an Ethernet network and reducing the overall cost of networking.

By offering a standards-based means to add reliability to Ethernet, DCB offers data center managers a vital tool for protecting their investments in the increasingly strategic data center network.

Bigger pipes and consolidation

Data centers have changed profoundly over the past decade. Continued adoption of virtualization has driven deployments of both multi-core and blade server platforms, which in turn has spurred storage consolidation. Organizations have also come to rely

Data center architects need the ability to classify and prioritize different data flows.

on Ethernet for such nontraditional applications as shared storage, voice telephony, streaming media, and on-demand delivery of ERP and CRM resources. In the meantime, cutting-edge application models – including private and public clouds, distributed-compute applications and virtual desktop architectures – have gained strategic importance. All of these trends contribute to accelerating growth in the quantity and complexity of enterprise data, and put a premium on storage availability and storage fabric bandwidth.

With these trends in play, research firm Gartner, Inc. forecasts global vendor shipments of enterprise 10GbE switch ports to grow at a rate of 41.3%, from 1.8M to 50.1M, between 2009 and 2016. By 2016, Gartner projects vendor revenues from the sale of 10GbE switches worldwide to reach \$8.7B. As organizations invest in new switching and network management technologies, opportunities to extend their value through fabric consolidation will become increasingly essential.

Extending Ethernet's relevance and long-term value

Fortunately, IT executives can take stock in DCB's ascendance as a data center staple. Ongoing standards work pursued jointly within the Internet Engineering Task Force (IETF) and the Institute of Electrical and Electronics Engineers (IEEE) has resulted in the collaborative, multivendor development of DCB. This has helped to drive efficiency into storage and other network applications, while minimizing proprietary, quasi-DCB implementations, thus simplifying the IT executive's job of deciding among different vendors' solutions. DCB support is a critical enabler for Fibre Channel over Ethernet (FCoE) and for RDMA over Converged Ethernet (RoCE, a protocol intended to enable Infiniband applications over Ethernet). Although iSCSI storage does not require it, DCB offers strategic value, given its ability to classify and prioritize iSCSI traffic on a converged 10GbE fabric. Indeed, the broad and rapidly expanding adoption of iSCSI storage worldwide may well compel vendors to support iSCSI-over-DCB by default within the foreseeable future.

A critical requirement for new infrastructures and point refreshes

DCB delivers many of the standards-based advantages long offered by Ethernet – cost-effectiveness, versatility and life-cycle value – while adding control. Although data center architects should include DCB support as a must-have criterion for both new infrastructures and point upgrades, they should note that this support is no simple yes/no checkbox item. For starters, to leverage DCB, data center managers need to verify application-specific DCB support across all storage interfaces, switches, converged network adapters (CNAs) and host operating systems in the data path. In addition, certain applications require specific DCB implementations (as defined in "type-length-value," or TLV, elements within the DCB protocol set). By default, DCB support may often be limited to FCoE; whether an organization uses iSCSI storage today, or stands to adopt it in the future, iSCSI-over-DCB support is crucial.

Given their evolution to date, data center fabrics stand to gain even more strategic importance, while transforming at an ever-faster pace. With this trajectory, DCB offers a vital tool for protecting investments in storage and other data center segments. For this reason, the impact of product-level variances in DCB support can be significant. Data center decision makers who exercise DCB due diligence today could make the difference between a robust storage fabric and one that grows obsolete within a few years.

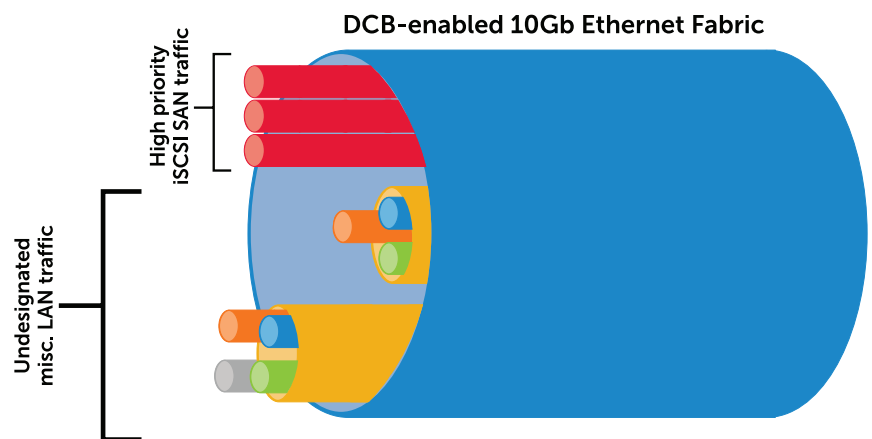

DCB lets organizations extend the value of their data center fabrics by enabling the consolidation of iSCSI, FCoE, Infiniband, and other high-priority traffic flows on a single Ethernet network.

¹Gartner, Inc., Forecast: Enterprise Network Equipment by Market Segment, Worldwide, 2009-2016 (published September 21, 2012).

For more information, go to www.DellStorage.com/StorageNetworking

